

SECTION B-B
SCALE 1 : 1

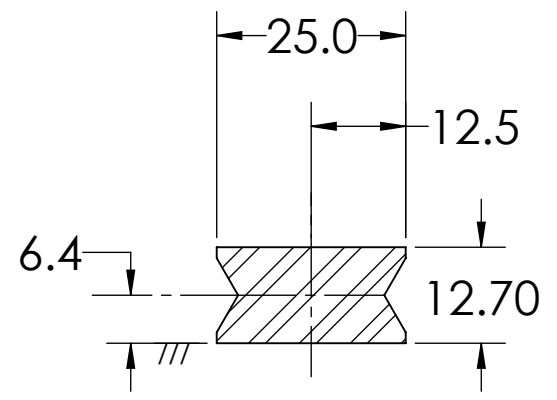

SECTION A-A
SCALE 1 : 1

NOTES:
1) ALL DIMENSIONS ARE SHOWN IN mm

UNLESS OTHERWISE SPECIFIED:			NAME	DATE
X.XXX = CRITICAL / INSPECTION			DRAWN	MAB 05-07-2019
TOLERANCES	INCHES	MM	APPROVED	
ANGULAR	±.5 DEG	±.5 DEG		
ONE PLACE DECIMAL	±.050"	±1.00mm		
TWO PLACE DECIMAL	±.010"	±.250mm		
THREE PLACE DECIMAL	±.005"	±.100mm		
GEOMETRIC TOLERANCING PER: ANSI/ASME Y14.1 STANDARD				
MATERIAL	Material <not specified>			
FINISH				
DO NOT SCALE DRAWING				
THIRD ANGLE PROJECTION				

TPA, FORT MILL SC

DESCRIPTION:			
CR40-90 DEGREE TURN DETAIL			
SIZE	DWG. NO.	REV	
B	CR40-150-90 DEGREE TURN	A	
SCALE: 1:2	WEIGHT:	SHEET 1 OF 1	

PROPRIETARY AND CONFIDENTIAL
THE INFORMATION CONTAINED IN THIS DRAWING IS THE SOLE PROPERTY OF THE PRECISION ALLIANCE (TPA) LOCATED IN FORT MILL, SOUTH CAROLINA. ANY REPRODUCTION IN PART OR AS A WHOLE WITHOUT THE WRITTEN PERMISSION OF TPA IS PROHIBITED.