

CREATIVE MOTION SYSTEMS

# Stainless Rolled Ball Screws

KSS Stainless Rolled Ball Screw Catalogue  
Vol.47



**kss** CO.,LTD.

# KSS Stainless Rolled Ball Screws

## Features

- High ability to Rust prevent and no need to be coating.
- Environmental-friendly rather than black-coating.
- Better cost performance compared to Ground type Ball Screw.



## Combination of Shaft dia & Lead

Below table describes KSS stainless Rolled Ball Screw outside diameter and lead combination.

Unit:mm

Shaft dia.	Lead	1	2
6		○	
8		○	○
10			○

## Specifications

- Accuracy & Axial clearance

Axial clearance and lead error are different in each accuracy grade. Please refer to Table below for combination of axial clearance and lead accuracy. Ball Screws with C7 and C10 accuracy are provided as KSS Standard. For mounting accuracy, please refer to KSS catalogue.

Unit:mm

	Cumulative Lead error	Axial-clearance
Ct7	$2 \times 0.052 \times \text{thread length} / 300$	0.020 or less
Ct10	$2 \times 0.210 \times \text{thread length} / 300$	0.050 or less

- Material and Surface Hardness

Table below describes KSS Stainless Rolled Ball Screw's material, heat treatment and hardness.

Parts	Material & Heat Treatment	Surface hardness
Shaft	SUS440C(Induction hardening)	Min. HRC55
Nut	SUS440C(Vacuum hardening)	Min. HRC55

- Lubrications

Generally, KSS Stainless Rolled Ball Screw uses KSS original grease, MSG No.2, if there is no designation. To require to use special grease, please consult or provide with your grease to KSS.

KSS also provides our original grease, MSG No.2 itself only if you want, please ask KSS.

## Ball Nut specifications & Dimensions

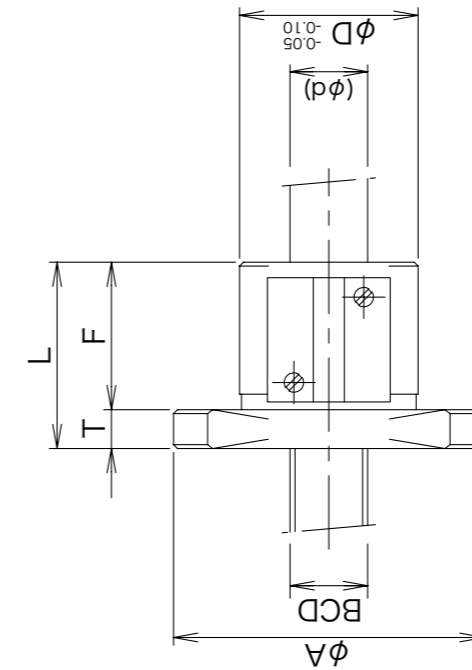
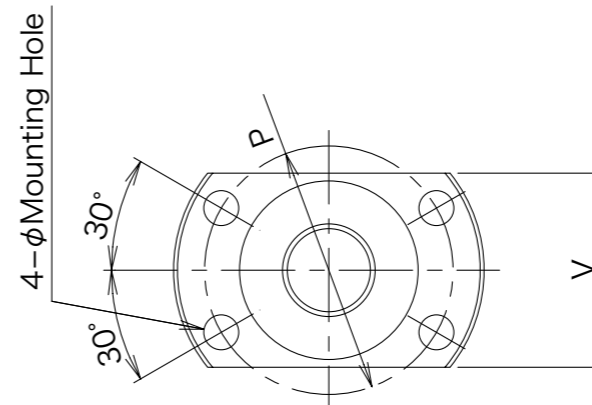

Shaft dia. (φd)	Max. limit
φ 6mm	300mm
φ 8mm	400mm
φ 10mm	400mm

Unit:mm

Model Number	Shaft dia	Lead	Ball size	BCD	Number of Circuits	Basic Load Rating		Nut dimensions							
						Ca (N)	Coa (N)	D	A	T	F	L	V	P	Mounting Hole
SSR0601	6	1	0.8	6.15	3.7x1	580	960	13	26	4	13	17	16	20	For M3
SSR0801	8	1	0.8	8.15	3.7x1	660	1320	16	29	4	13	17	18	23	For M3
SSR0802	8	2	1.5875	8.30	3.7x1	2050	3280	20	37	5	19	24	22	29	For M4
SSR1002	10	2	1.5875	10.30	3.7x1	2300	4240	23	40	5	19	24	25	32	For M4

Note 1) When you need a special nut type, please consult with KSS.

Note 2) All of KSS Stainless Rolled Ball Screws are custom-made including end journal re-work. Please describe your end journal design when you order.

Note 3) If your shaft length exceed our maximum limit, please consult with KSS.

## Handling precautions for Ball Screws

Ball Screws are precision components, and must be handled carefully in accordance with the instruction below.

### 1) Critical speed and Axial Load.

Ball Screws have the maximum limit of speed and axial load depending on material, mounting method etc.

When design Ball Screw, please consult with **KSS** engineering about the customer's usage.

### 2) Dust Prevention

In Ball Screws, if dust or other contaminations intrude into the Ball Nut, its performance may be reduced and wear will be accelerated.

**KSS** Stainless Rolled Ball Screws do not have dust seals at both end of nut, bellows or telescopic tube or other dust proofing device should be recommended.

### 3) Lubrication

In Ball Screw use, lubricant selection is an extremely important issue.

**KSS** Stainless Rolled Ball Screw is already lubricated; however if Ball Screws are to be stored for long periods, please request **KSS** to coat with a anti-rusting oil.

Since anti-rusting oil is not lubrication (grease/oil), Ball Screw should be washed off oil with clean kerosene and apply lubrication before using Ball Screw.

Please check the lubricant condition every 2 or 3month.

If grease is contaminated, remove old grease, and replace with new grease.

### 4) Unbalanced Load

In the design stage, it must be insured that radial loads and moment loads do not act directly on the Ball Screws.

If these loads act on the Ball Screw, ball load uniformity is lost, and the life of the Ball Screws is drastically reduced.

Misalignment of the Bearings which support the threaded shaft, or of the brackets which fix the nuts, or inaccurate angle or alignment of the nut mounting surface or inaccurate alignment of the guide surface, etc., will affect the Ball Screw, since an unbalanced load will result which will degrade the accuracy greatly.

### 5) Ball Nut falling by weight

If Ball Screws are not preloaded, and if the screw threads extend up to the screw shaft cut end, the nut will move of its own weight; therefore care must be taken that the nut does not come off the end of the screw shaft.

To prevent this from occurring, a stopper may be installed on the end of the shaft.

### 6) Alteration and Processing

Alteration or processing of the complete product or parts of Ball Screws may degrade the accuracy of the parts.

Particularly, any alteration and processing by the customer invalidates **KSS**'s warranty.



**KSS** CO.,LTD.

HEAD OFFICE: 1-22-14, Yaguchi, Ota-ku, Tokyo, Japan  
Tel. +81-3-3756-3921 Fax. +81-3-3756-3191  
URL: <http://www.kss-ball screw.com>  
<http://www.kss-superdrive.co.jp>