

LINEAR ROLLER SYSTEM with MR rail and R, R.T, R.S sliders

The MR Series Linear Rail System consists of a C-section steel rail with internal convex raceways, where robust double row ball bearing rollers travel. The high precision rollers are lubricated for life and protected with 2RS seals. Sliders are available with three or five rollers, including eccentrics to adjust the bearing preload. Both ends of the sliders are equipped with polyamide wipers to remove debris from the raceway and grease impregnated felt wipers to lubricate the raceways for long life with minimal maintenance.

The MR rail system is especially equipped for harsh environments where contamination is a problem. Most bearing systems utilize a groove that a roller or ball travel within. These grooves capture and hold debris that eventually cause the bearing to fail. The convex raceway of the MR Series provides a place for debris and other contaminants to be pushed aside by the rollers. This feature enables the MR Series to function in environments where other bearings quickly fail.



Sliders Series: RV, RP, RA

R Sliders Series are made of zinc plated steel with mounting holes parallel to the roller axis and perpendicular to the direction of preferred loading. The sliders have sealed rollers, axial wipers, and longitudinal seals for optimal protection of the internal parts and a sealing strip to prevent accidental tampering of the fixed rollers.

The R Series Sliders are available in 3 sizes and with either 3 or 5 rollers.

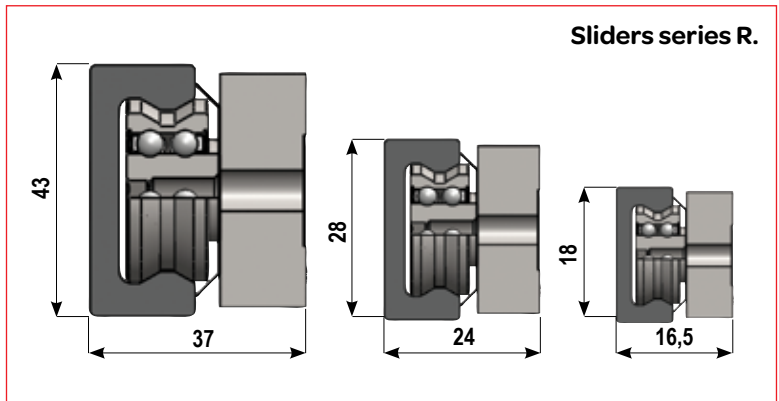

Sliders Series: RVT, RAT, RPT, RFT

R.T Sliders Series are made of zinc plated steel with mounting holes perpendicular to the roller axis and parallel with the direction of preferred loading. The sliders have sealed rollers and axial wipers for protection of the internal parts. The R.T Series Sliders are available in 2 sizes and with either 3 or 5 rollers.

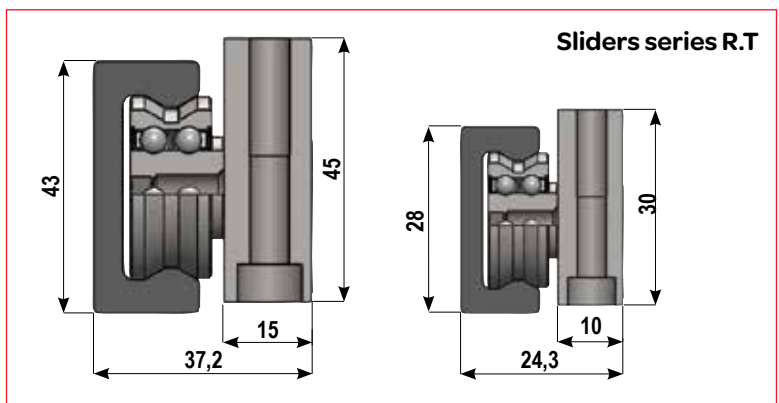

Sliders Series: RVS, RAS, RPS, RFS

The R.S Sliders Series have a very slim body to obtain the most compact slider possible, without sacrificing performance. They also offer both threaded and through hole mounting options. The standard slider body is made from zinc plated steel but is also available in all Stainless Steel construction for higher corrosion resistance.

The R.S Series Sliders are available in 2 sizes, 2 materials, and with either 3, 4 or 5 rollers.

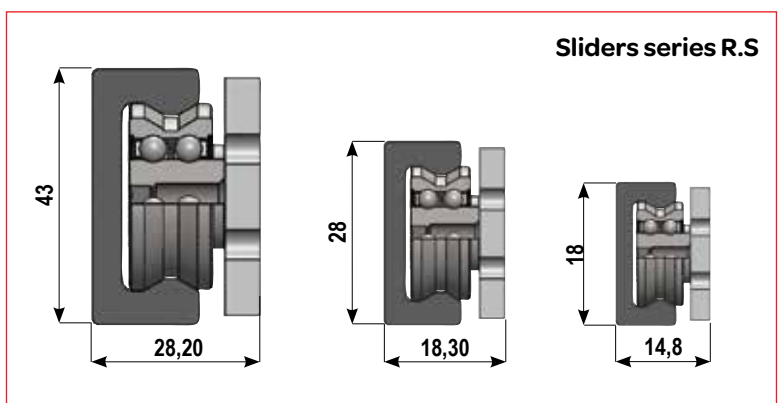

Sliders are available with either 3 or 5 rollers. For the 3 roller version, the first and third roller are fixed, concentric rollers that run on the same raceway. The second roller is eccentric and runs on the opposite raceway.

The eccentric feature is used to adjust the slider preload in the rail. For the 5 roller version, the two lateral and the central roller are fixed, and run on the same raceway.

The second and fourth roller are eccentric and run on the opposite raceway. The eccentric feature is used to adjust the slider preload in the rail. Because one raceway contacts more rollers than the other raceway, the sliders have a preferred loading direction.

The slider is marked with two small circular notches indicating the direction with the most rollers and direction of preferred loading. Care during assembly is required to ensure the maximum load capacity of the system is achieved.

The rollers used in the sliders consist of two different geometries to achieve different levels of constraint within the linear rails. Guiding Rollers (RCV, REV) contact the raceway at two points creating a well constrained rollers on the raceway. Floating Rollers (RCP, REP) engage only the peak of the raceway which constrains it radially but allows it to float in the axial direction between the two shoulders.

By using different combinations of guiding and floating rollers, sliders with different performance characteristics are obtained. These combinations can be used to avoid the binding that can occur because of alignment problems when mounting two linear bearings in parallel.

Guiding Sliders: By utilizing all guiding rollers RV, RTV, and RSV sliders are obtained, they are fully constrained and will support loads and moments in all directions with the greatest capacity in the radial direction.

Floating Sliders: By utilizing all floating rollers to construct RP, RSP, and RTP sliders are obtained, these sliders are able to carry full load in the radial direction and also float and rotate a small amount in the rail without affecting the preload or quality of the movement and without binding. Floating sliders are used in 2 rail systems to absorb parallelism errors in the mounting surfaces. For size 43 sliders, RF, RFT, and RFS sliders are available which allow even greater axial displacement.

Rotating Sliders: By mixing guiding and floating rollers to construct RA, RSA, and RTA sliders are obtained, these sliders are able to carry full load in the radial direction and also rotate slightly without affecting the preload or quality of movement. These sliders also retain the ability to guide the payload as it travels. Rotating sliders are used in 2 rail systems to absorb angular errors in the mounting surfaces, that cause traditional bearings to bind.

Combination: By combining a floating and rotating slider together in a 2 rail system, the MR rail system can carry and guide a full payload while compensating for parallelism and angular errors in the rail mounting surfaces. These types of errors are often found when mounting to welded frames, structural Aluminum frames, sheet metal structures, etc. The self alignment capability can eliminate the need to machine the rail mounting surfaces.

Roller loading position

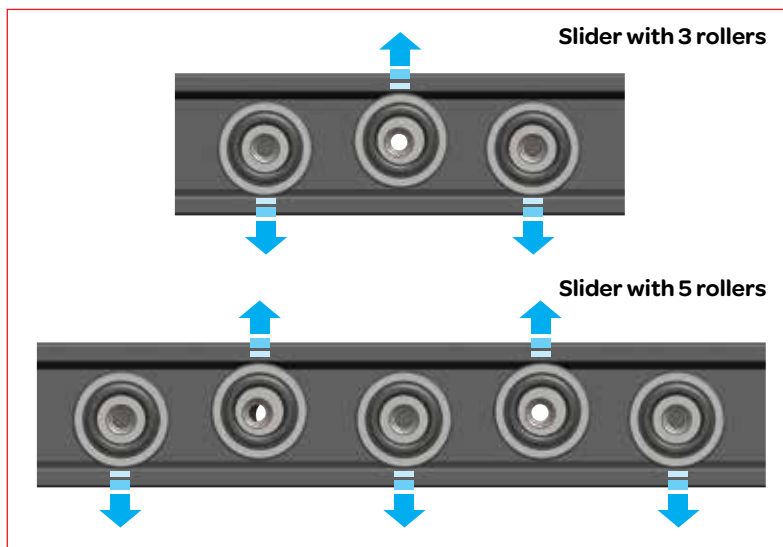

Roller contact points

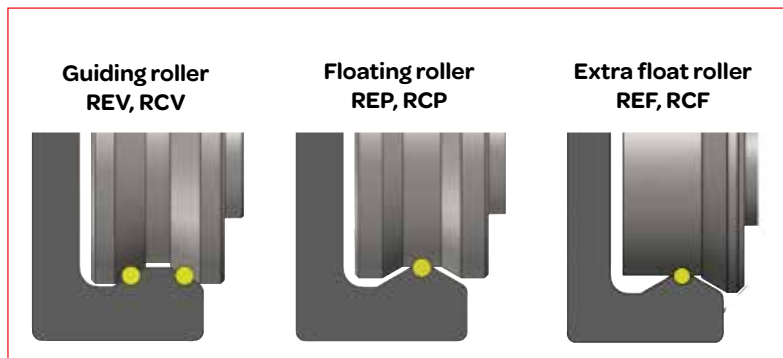

Slider contact points

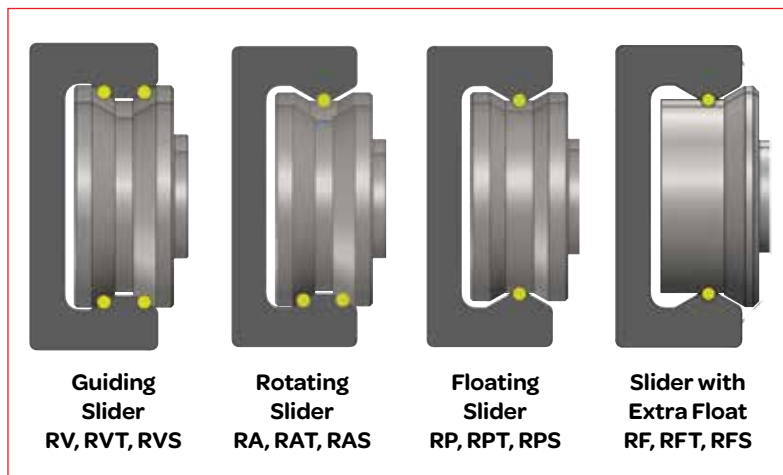

Selfaligning combination

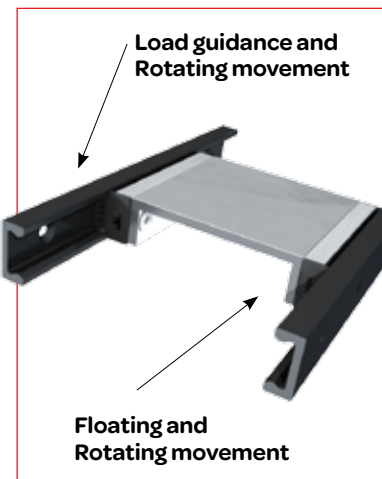
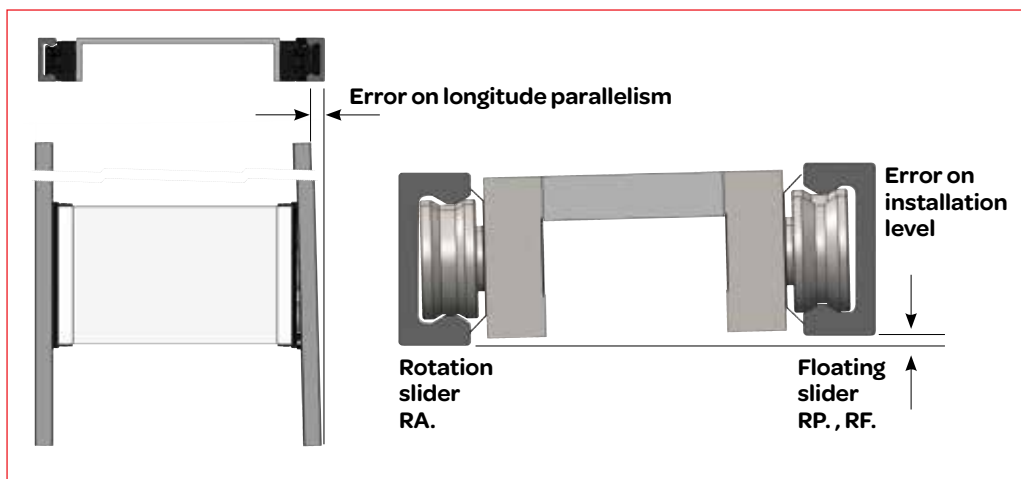

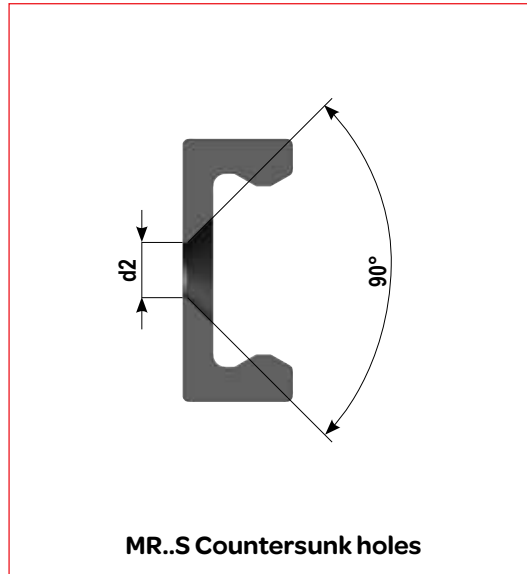
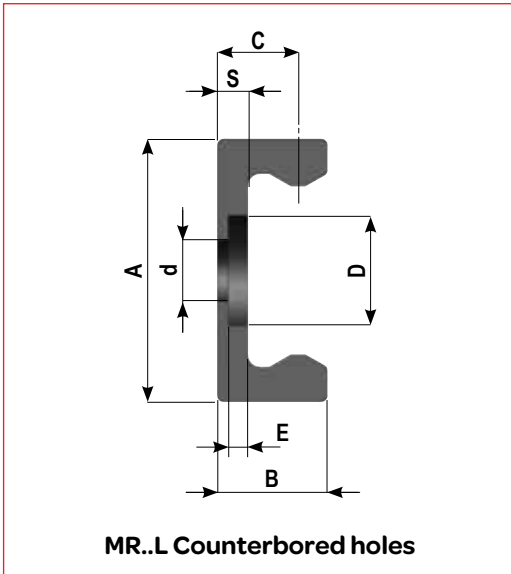
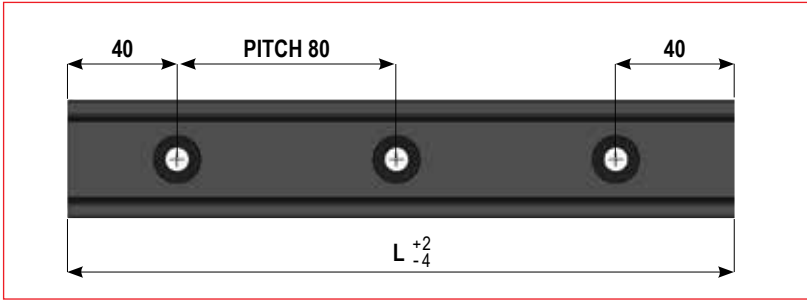

(Example of order code: MR28L - 640)

Code	A (mm)	B (mm)	C (mm)	S (mm)	D (mm)	d (mm)	E (mm)	d2 (mm)	Screw type	Weight (Kg/m)
MRG18S	18	9,5	7,1	2,8				4,5	M4 DIN7991	0,68
MRG18L					9	5	1,9	M4 TORX *		
MR28S	28	12	8	3				5,5	M5 DIN7991	1,25
MR28L					11	6	2	M5 TORX *		
MR43S	43	18	13,2	5				8,5	M8 DIN7991	3,04
MR43L					18	10	3,2	M8 TORX *		

* Special flat-head TORX screws supplied with rails.

Screw type		G (mm)	S (mm)	V (mm)		Tightening Torque
M4 TORX	M4	8	1,9	8	T20	3,5 Nm
M5 TORX	M5	10	2	10	T25	10 Nm
M8 TORX	M8	16	3	16	T40	20 Nm

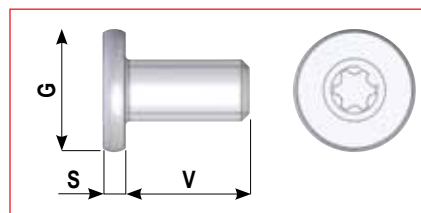

Length L (mm)		
MRG18	MR28	MR43
160		
240	240	
320	320	
400	400	400
480	480	480
560	560	560
640	640	640
720	720	720
800	800	800
880	880	880
960	960	960
1040	1040	1040
1120	1120	1120
1200	1200	1200
1280	1280	1280
1360	1360	1360
1440	1440	1440
1520	1520	1520
1600	1600	1600
1680	1680	1680
1760	1760	1760
1840	1840	1840
1920	1920	1920
2000	2000	2000
2080	2080	2080
2160	2160	2160
2240	2240	2240
2320	2320	2320
2400	2400	2400
2480	2480	2480
2560	2560	2560
2640	2640	2640
2720	2720	2720
2800	2800	2800
2880	2880	2880
2960	2960	2960
	3040	3040
	3120	3120
	3200	3200
	3280	3280
	3360	3360
	3440	3440
	3520	3520
	3600	3600
	3680	3680
	3760	3760
	3840	3840
	3920	3920
	4000	4000

TECHNICAL DATA

MR Series Rails are made in 3 sizes 18mm, 28mm and 43mm with two types of mounting holes: MR .. L with counterbored mounting holes for special low head TORX mounting screws that are provided with the rail. MR .. S with countersunk mounting holes for UNI-standard ISO5933 fasteners. The rail has a "C" shaped cross-section with interior, convex raceways. The convex raceways are polished for smooth, low noise motion. The interior raceways are protected from acci-

dental bumps and other damages, that can spoil the surface. The shape also protects the rollers from similar types of damages. MR Series Rails are made from carbon steel that is hardened through high depth nitriding. The rails are then treated with the innovative TRACE-NOX process, which delivers excellent corrosion resistance. This treatment is not a plating which can flake off but instead penetrates and alters the material surface. The result is a very hard and durable, corrosion resistance linear rail, that is black in color, due to the microimpregnation of oil and antioxidants.

3 Rollers slider for R. series

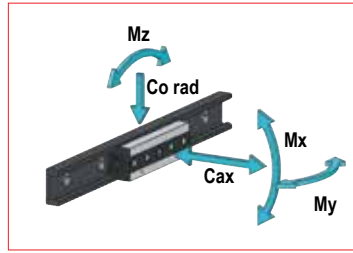
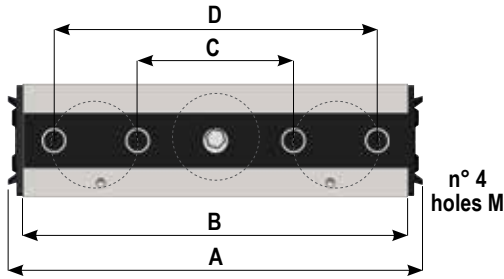

RV Guiding slider dimensions

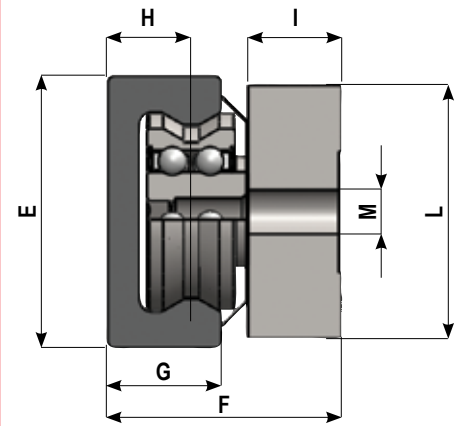

5 Rollers slider for R. series

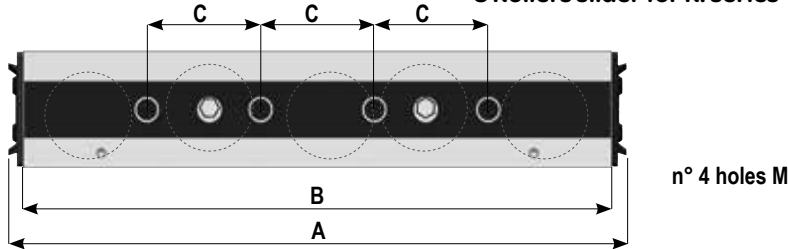

Code	Rail type	E (mm)	F (mm)	G (mm)	H (mm)	I (mm)	L (mm)	M (mm)	A (mm)	B (mm)	C (mm)	D (mm)	Weight (g)	Dynamic coeff. C (N)	Load capacity				
															Co rad (N)	Co ax (N)	Mx (Nm)	My (Nm)	Mz (Nm)
RVG18-3	MRG18	18	16,5	9,5	7,1	4,8	16	M5	78	70	20	52	75	3300	1600	690	3	9	15
RPG18-3														3300	1600	0	0	0	15
RAG18-3														3300	1600	460	3	9	15
RVG18-5														4455	2160	1150	6	18	48
RPG18-5														4455	2160	0	0	0	48
RAG18-5														4455	2160	690	6	18	48
RV28-3	MR28	28	24	12	8	9,7	25	M5	102	94	35	78	240	6000	3200	1380	9	27	46
RP28-3														6000	3200	0	0	0	46
RA28-3														6000	3200	920	9	27	46
RV28-5														8100	4320	2300	18	46	120
RP28-5														8100	4320	0	0	0	120
RA28-5														8100	4320	1380	18	46	120
RV43-3	MR43	43	37	18	13,2	14,8	40	M8	147	136	55	114	730	14200	7200	3210	32	92	155
RP43-3														14200	7200	0	0	0	155
RA43-3														14200	7200	2080	32	92	155
RF43-3														14200	7200	0	0	0	155
RV43-5														19170	9720	5350	64	165	418
RP43-5														19170	9720	0	0	0	418
RA43-5														19170	9720	3560	64	165	418
RF43-5														19170	9720	0	0	0	418

RA series – Rotating slider

Series	(+/-) a°
RA18	1,5
RA28	1,5
RA43	1,5

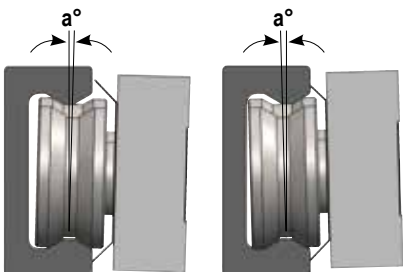

RP series – Floating slider

Series	(+/-) a°	F Min	F Max
RP18	1,5	16	17
RP28	1,5	23,4	24,6
RP43	1,5	36	38

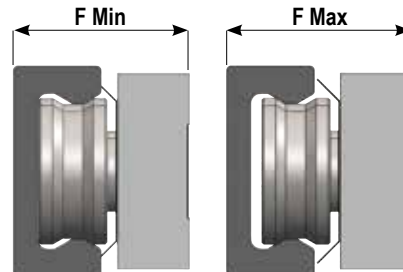

RF series – Extra floating slider

Series	(+/-) a°	F Min	F Max
RF43	1,5	36	40

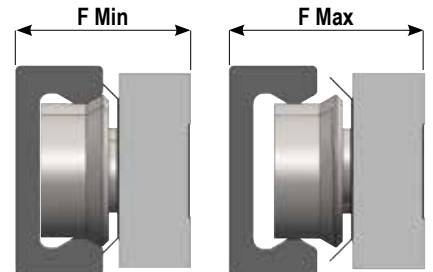

Sliders of series RVT, RAT, RPT, RFT, provide fixing holes parallel to the preferable radial load direction. As the slider body protrudes from rail level, the moving part can be resting on top of the linear system, while being fixed from above with threaded holes or from below with through passing holes.

Slider type	Threaded holes for top mounting		Passing holes for bottom mounting, screw UNI 5931			
	d1 (mm)	N (mm)	Tipo vite	d2 (mm)	S (mm)	D (mm)
R.T28-3	M6	15	M5	Ø5,5	5	Ø9
R.T28-5						
R.T43-3	M8	20	M6	Ø6,5	6,5	Ø11
R.T43-5						

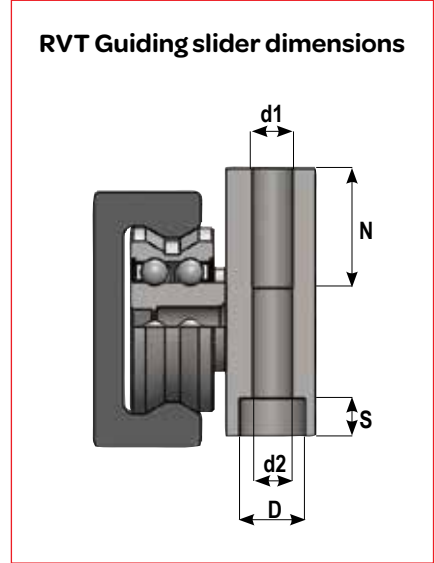

The A and B versions differ only in the arrangement of the rollers providing maximum radial load capacity either toward or against the mounting surface. The preferential loading direction is marked by two circular notches. (Ordering code example: RVT28-3A or RVT28-3B) The slider body allows two methods of mounting. One method is to pass a fastener through the counterbored hole into the payload or to pass a fastener through the payload into the tapped hole at M.

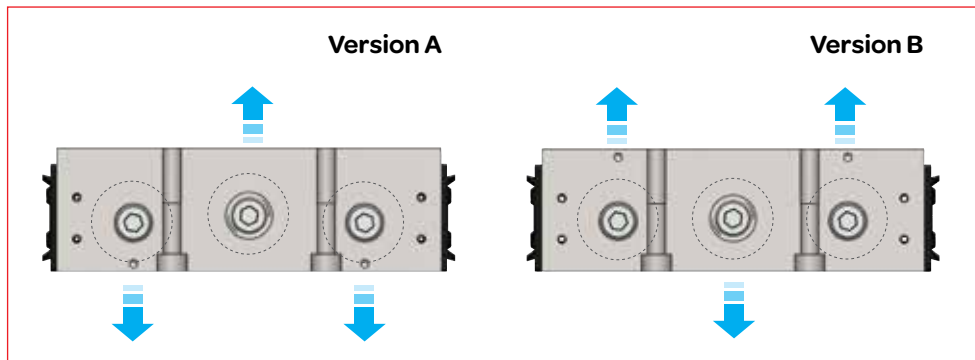
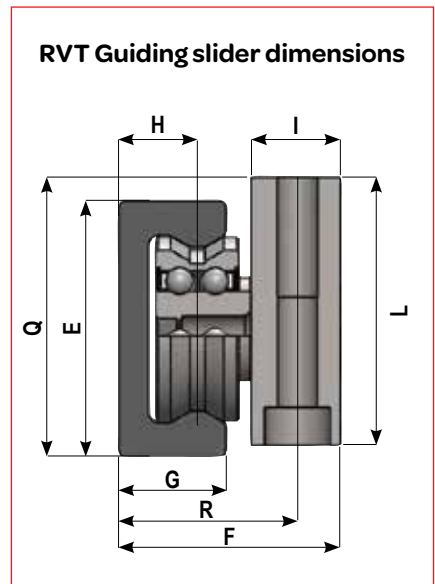

Rotation slider series RAT

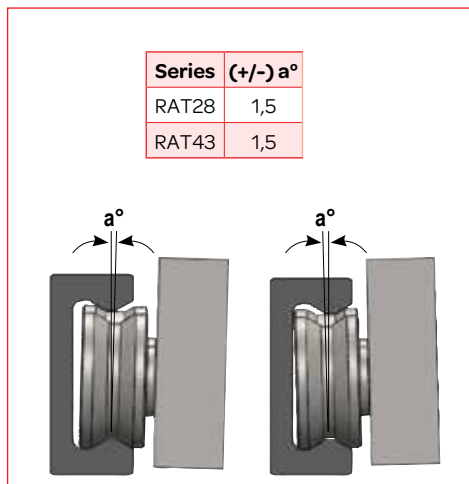

Floating slider series RPT

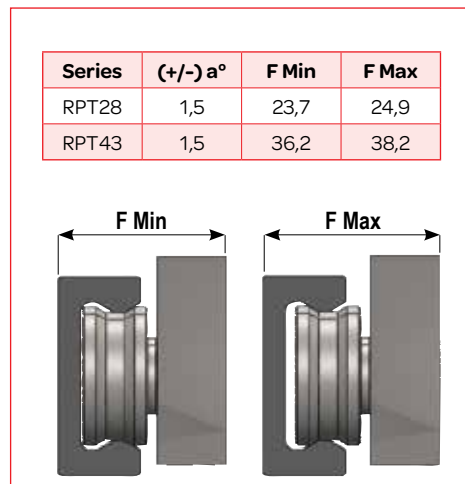

Extra floating slider series RFT

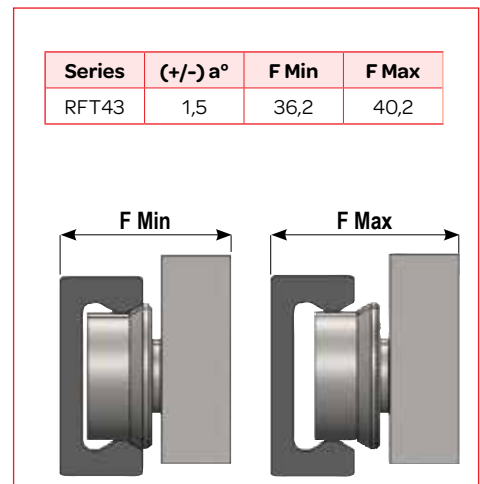

3 Rollers slider for R.T series – Version A

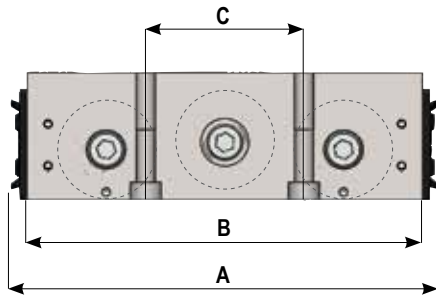

3 Rollers slider for R.T series – Version B

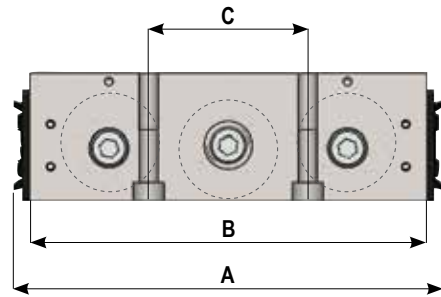

5 Rollers slider for R.T series – Version A

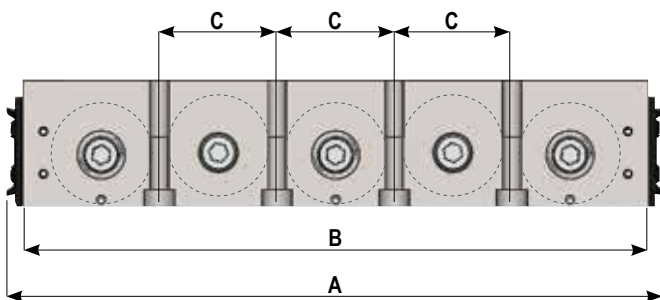

5 Rollers slider for R.T series – Version A

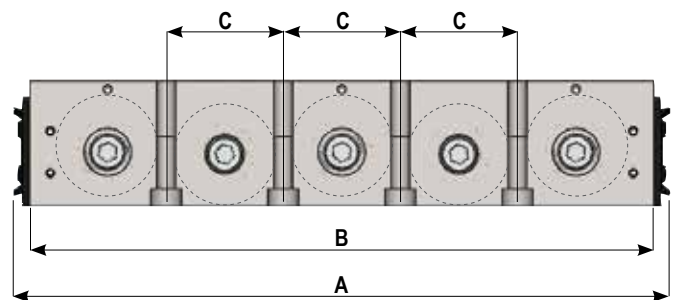

Code	Rail	E (mm)	F (mm)	G (mm)	H (mm)	I (mm)	L (mm)	N (mm)	Q (mm)	R (mm)	A (mm)	B (mm)	C (mm)	Weight (g)	Dynamic coeff. C (N)	Load capacity				
																Co rad (N)	Co ax (N)	Mx (Nm)	My (Nm)	Mz (Nm)
RVT28-3.	MR28	28	24,3	12	8	10	30	15	32	19,5	102	94	36	280	6000	3200	1380	9	27	46
RPT28-3.															6000	3200	0	0	0	46
RAT28-3.															6000	3200	920	9	27	46
RVT28-5.															8100	4320	2300	18	46	120
RPT28-5.															8100	4320	0	0	0	120
RAT28-5.	8100	4320	1380	18	46	120														
RVT43-3.	MR43	43	37,2	18	13,2	15	45	20	47	30	151	140	56	860	14200	7200	3210	32	92	155
RPT43-3.															14200	7200	0	0	0	155
RAT43-3.															14200	7200	2140	32	92	155
RFT43-3.															14200	7200	0	0	0	155
RVT43-5.															19170	9720	5350	64	165	418
RPT43-5.	235	224	42	1200	19170	9720	0	0	0	418										
RAT43-5.					19170	9720	3210	64	165	418										
RFT43-5.					19170	9720	0	0	0	418										

Example of order code.

RVT28-3B : Guiding slider with 3 roller, version B

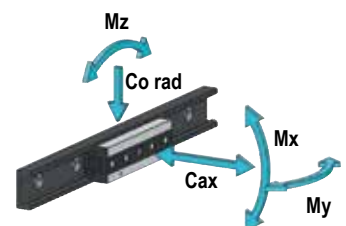

Very compact slider, with slim strong slider body, for application with limited space. Performance like standard R-sliders including self aligning concept. Featuring extra long 4-roller version to optimize performance with only 1 slider, instead of 2 sliders.

Guiding slider series RVS.

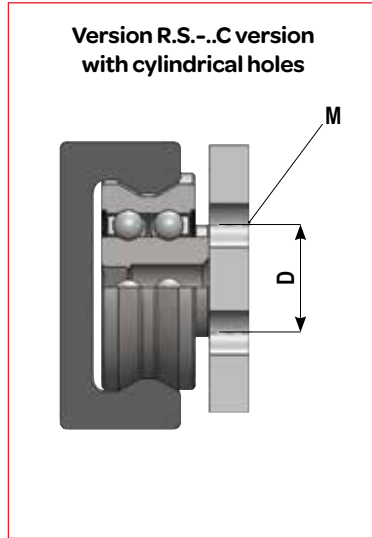
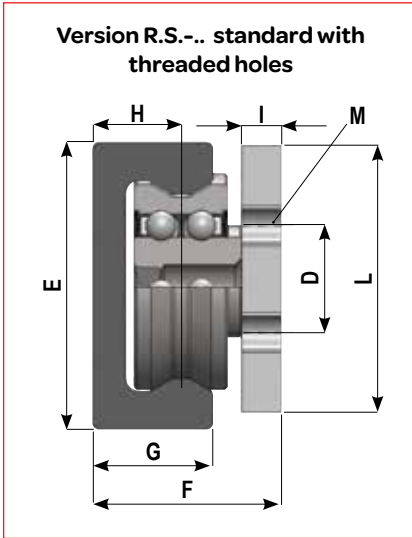

The sliders are available in standard version with threaded fixing holes R.S-.. and in version ...C with through passing holes for inside fixing with standard cylindrical screws DIN912, with no interference with the rollers.

Slider type	M	Type of fixing screws
R.GS18-..	M4	
R.GS18-..C	Ø 4,5	M4 DIN912
R.S.28-..	M5	
R.S.28-..C	Ø 5,5	M5 DIN912
R.S.43-..	M6	
R.S.43-..C	Ø 6,5	M6 DIN912

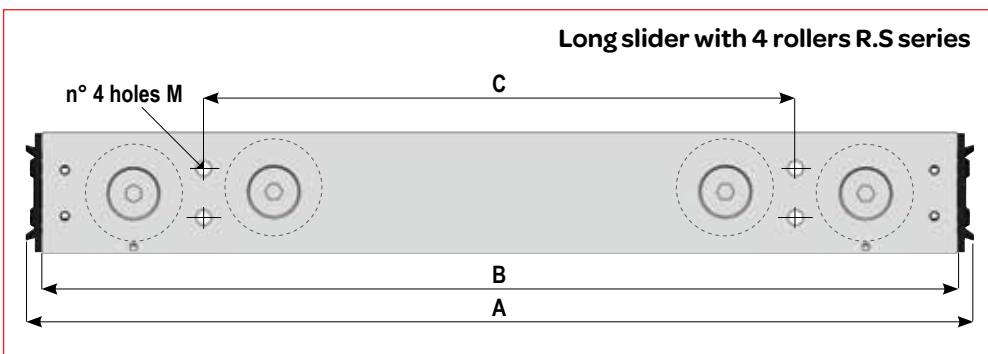
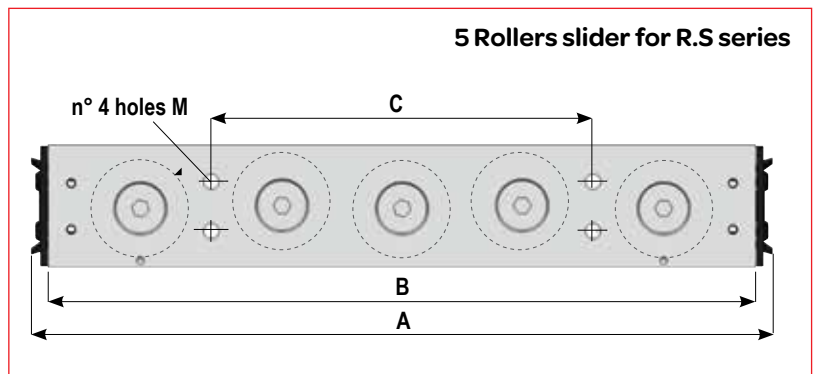
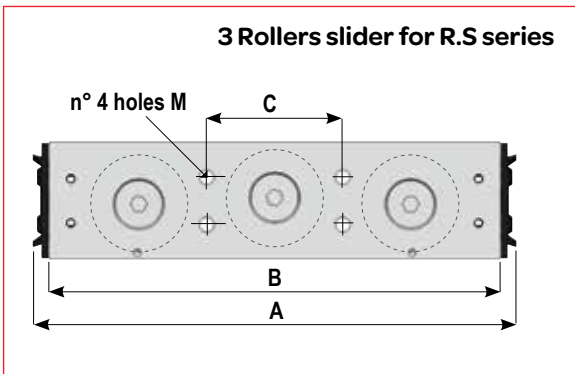

INOX Versions

The sliders in dimensions 28 and 43 are also available in INOX for version RVSX, RASX and RPSX. The rollers are hardened AISI 440C, while slider body AISI 304. The load capacities are identical to the standard version of RVS and RPS.

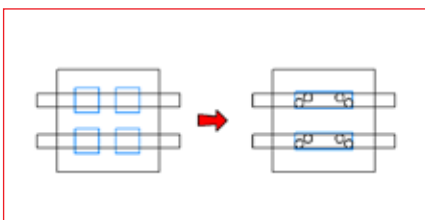

The extra long slider body for 4-roller sliders R.S.-4L are made to offer an economical alternative for the many cases where 2 sliders are used, merely for proportional reasoning, rather than for load capacities. Also, option for very economical sliders for high M_z and M_y moment capacities.

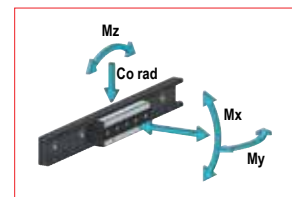

Example of order codes.

- RVS28-3** : Guiding Slim-slider with 3 roller
- RPS43-4LC** : Extra long rotation Slim-slider with 4 rollers and cylindrical fixing holes
- RVSX28-5** : INOX guiding Slim-slider with 5 rollers

Rotating slider RAS series

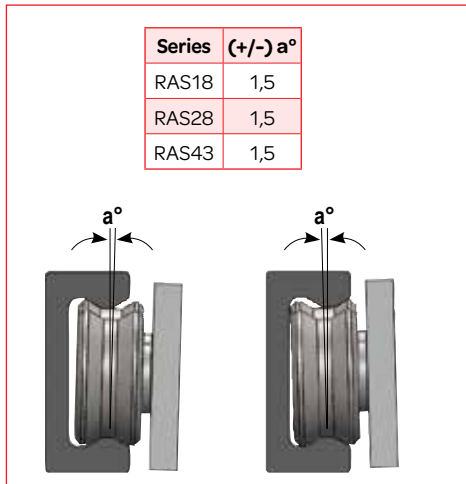

Floating slider RPS series

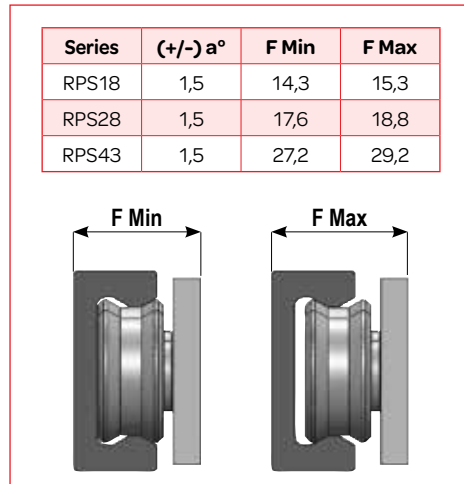

Extra floating slider RFS series

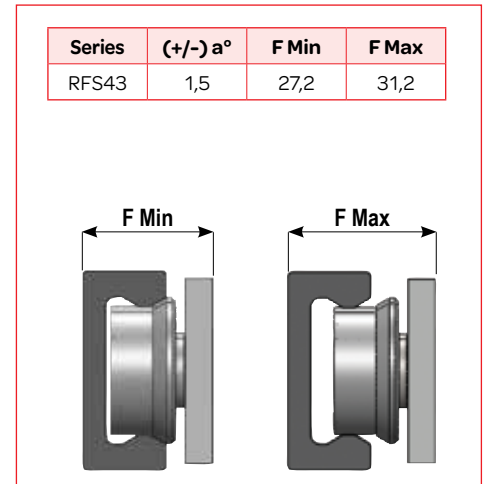

Code	Rail Type	E (mm)	F (mm)	G (mm)	H (mm)	I (mm)	L (mm)	A (mm)	B (mm)	C (mm)	D (mm)	Weight (g)	Dynamic coeff. C (N)	Load capacity													
														Co rad (N)	Co ax (N)	Mx (Nm)	My (Nm)	Mz (Nm)									
RVGS18-3	MRG18	18	14,7	9,5	7,1	3	15	81	73	21	8	75	3300	1600	690	3	9	16									
RPGS18-3													3300	1600	0	0	0	16									
RAGS18-3													3300	1600	460	3	9	16									
RVGS18-5								MRG18	18	14,7	9,5		7,1	3	15	110	102	50	8	120	4455	2160	1150	6	19	49	
RPGS18-5																					4455	2160	0	0	0	49	
RAGS18-5																					4455	2160	690	6	19	49	
RVGS18-4L								MRG18	18	14,7	9,5		7,1	3	15	158	150	98	8		125	3300	1600	920	6	27	78
RPGS18-4L																						3300	1600	0	0	0	78
RAGS18-4L																						3300	1600	460	6	27	78
RVS.28-3.	MR28	28	18,3	12	8	4	25	114	106	32	10	140	6000	3200	1380	9	30	52									
RPS.28-3.													6000	3200	0	0	0	52									
RAS.28-3.													6000	3200	920	9	30	52									
RVS.28-5.								MR28	28	18,3	12		8	4	25	164	156	82	10	210		8100	4320	2300	18	52	130
RPS.28-5.																						8100	4320	0	0	0	130
RAS.28-5.																						8100	4320	1380	18	52	130
RVS.28-4L.								MR28	28	18,3	12		8	4	25	208	200	126	10		230	6000	3200	1840	18	73	202
RPS.28-4L.																						6000	3200	0	0	0	202
RAS.28-4L.																						6000	3200	920	18	73	202
RVS.43-3.	MR43	43	28,2	18	13,2	6	40	164	153	46	16	440	14200	7200	3210	32	98	165									
RPS.43-3.													14200	7200	0	0	0	165									
RAS.43-3.													14200	7200	1240	32	98	165									
RFS.43-3.								MR43	43	28,2	18		13,2	6	40	241	230	124	16	670		14200	7200	0	0	0	165
RVS.43-5.																						19170	9720	5350	64	180	440
RPS.43-5.																						19170	9720	0	0	0	440
RAS.43-5.								MR43	43	28,2	18		13,2	6	40	241	230	124	16		670	19170	9720	3210	64	180	440
RFS.43-5.																						19170	9720	0	0	0	440
RVS.43-4L.																						14200	7200	4280	64	257	698
RPS.43-4L.	MR43	43	28,2	18	13,2	6	40	311	300	194	16	750	14200	7200	0	0	0	698									
RAS.43-4L.													14200	7200	2140	64	257	698									
RFS.43-4L.													14200	7200	0	0	0	698									
RVS.43-4L.													14200	7200	0	0	0	698									

The ROLLERACE rollers are designed around a double-row precision ball bearing to guarantee both high radial and axial load capacities. The rollers are protected by a double lip sealing system (2RS) to assure long lifetime, even in difficult environments. The integrated roller pivot has concentric or eccentric shape, to allow for preload setting in the different systems.

The bearings are made to precision class DIN620 of core-hardened carbon steel. The rollers are available in series R.V with 2 contact points on the protruding

raceways to obtain, a rigid guiding movement.

The R.P has the rollers with some limited floating/compensation capacity, as only having one contact point at the central part of the raceways.

The R.F rollers offer much more floating capacity, as one side is completely flat (only rollers in size 43/63).

The rollers of size 28 and 43 are also available in INOX stainless steel series R..X. All made from AISI440 steel, core hardened and ground, for applications in corrosive ambients.



Only size 63

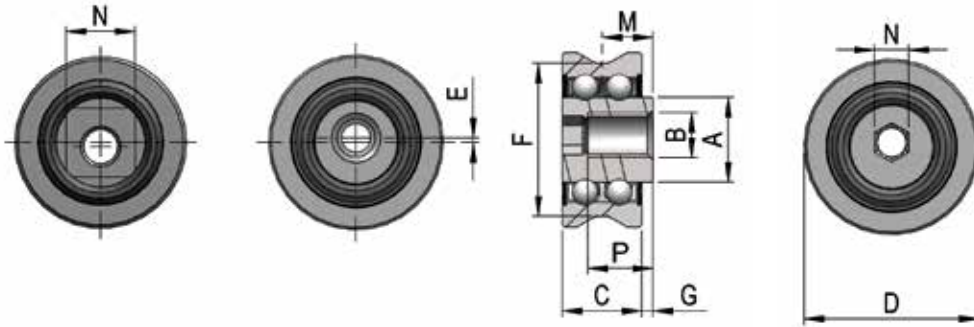

Guiding roller R.V

Floating roller R.P

Freely floating roller R.F

Plain roller R.U

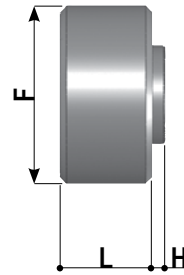
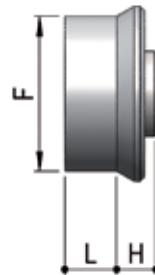
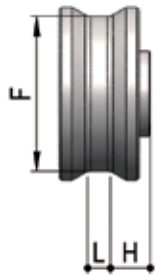
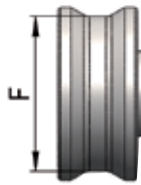

R. rollers for MR, FXR rails

Roller code	Type	E (mm)	D (mm)	C (mm)	M (mm)	G (mm)	N Flat key	A (mm)	B (mm)	P (mm)	R (mm)	F (mm)	L (mm)	H (mm)	Version	Lateral floating x	For rail	Dynamic coeff. C (N)	Load capacity (N)		Weight (g)
																			Co rad	Co ax	
RCV18G	concentric	0	13,2	7,0	4,6	1,1	Allen key 3	6,8	M4	5,4	8,8	11,4			guiding		MRG18	1650	800	230	10
REV18G	eccentric	0,4																			
RCP18G	concentric	0																			
REP18G	eccentric	0,4																			
RCV28	concentric	0	20,0	9,0	6,3	1,75	Allen key 4	10,8	M5	7,0	13,9	17,6			guiding		MR28	3000	1600	460	20
RCVX28	concentric	0																			
REV28	eccentric	0,6																			
REXV28	concentric	0																			
RCP28	concentric	0																			
RCPX28	concentric	0																			
REP28	eccentric	0,6																			
REPX28	eccentric	0,6																			
RCU28	concentric	0	17,8					9,7				17,8	9	1,8	plain	2 (+/-1)					
REU28	eccentric	0,6																			
RCV43	concentric	0	30,8									27			guiding						
RCVX43	concentric	0																			
REV43	eccentric	0,8																			
REXV43	concentric	0																			
RCP43	concentric	0	30,4	14,0	9,0	2,0	Allen key 6	15,0	M8	10,5	21,3	27,2	4,0	7,0	floating	2 (+/-1)	MR43 FXR	7100	3600	1070	50
RCPX43	concentric	0																			
REP43	eccentric	0,8																			
REPX43	eccentric	0,8																			
RCF43	concentric	0																			
REF43	eccentric	0,8																			
RCU43	concentric	0	27,2								27,2	14	2	plain	4,5 (+3/-1,5)						
REU43	eccentric	0,8																			
RCV63	concentric	0	42,4	15,7	10,95	3,1	Flat key 17 Outer dim. for KMR 63	22,1	M10	18,8		38,4			guiding		FXR	11200	6400	2000	80
REV63	eccentric	1,2																			

Position R referred to FXR rail is indicated at page 26