

Types and features

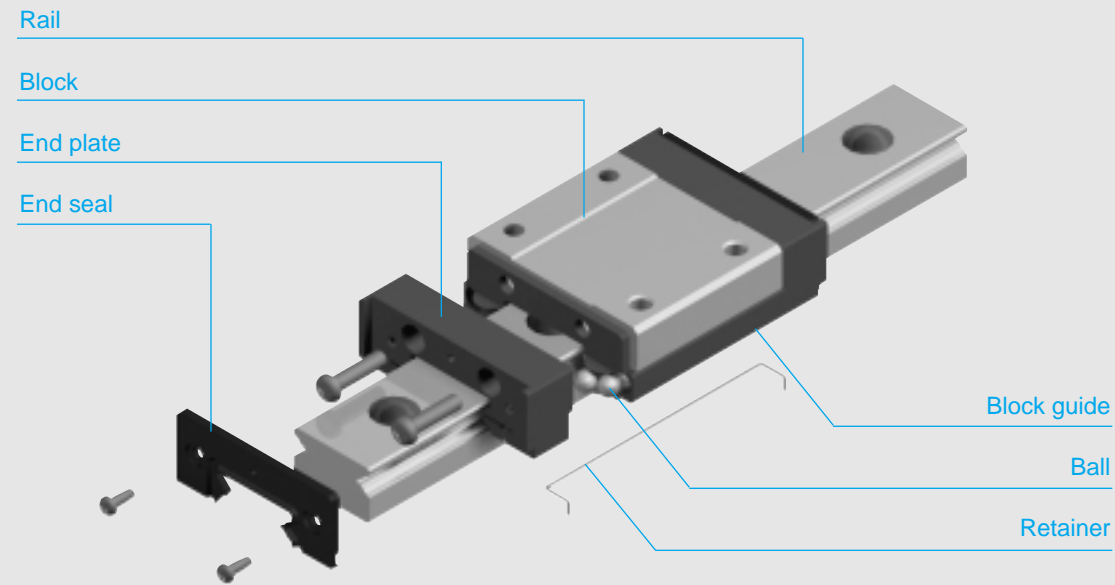

[Feature of structure]

SBC Miniature linear rail system utilizes two rows of ball bearings which make four point contact between the rail and block. This design achieves both a slim profile and high rigidity. The special engineered plastic is used for the end-plate allows for long life ball recirculation.

[Ball retention]

To retain the ball bearings inside the block, a wire retainer is used between the block and rail. With this retainer, the block can be carefully removed from the rail without losing ball bearings.

[Low noise]

With a ball return path made from engineered plastic, contact noise between the balls and block wall is removed, therefore achieving low noise.

[Smooth movement]

The steel block, ball returns, and end caps are carefully engineered to act as a single path enabling smooth operation in both horizontal and vertical applications.

[Excellent corrosion resistance]

Both the rail and block are made from stainless steel for excellent corrosion resistance. This is ideal for semiconductor, life science, LCD, or other clean room production environments.

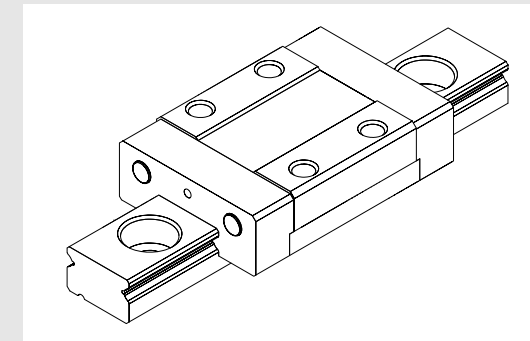

[SBM type]
Standard type of miniature.

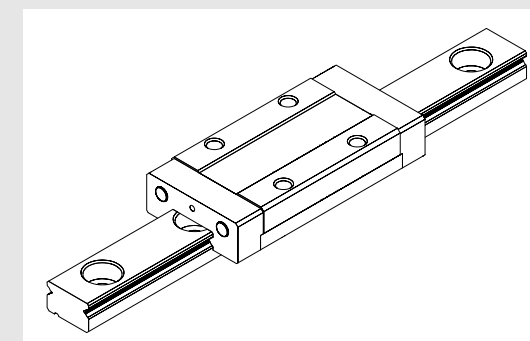

[SBML type]
Block length is modified type to increase load capacity.

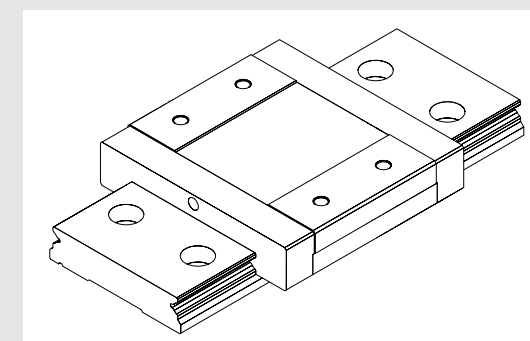

[SBMW type]
The width and length of linear block and rail are modified to increase load ratings and permissible moments.

Accuracy

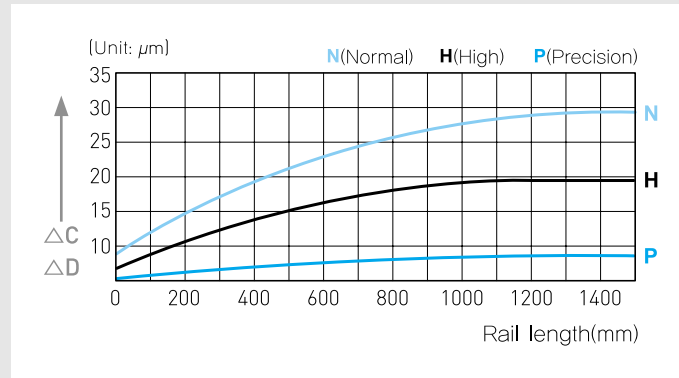
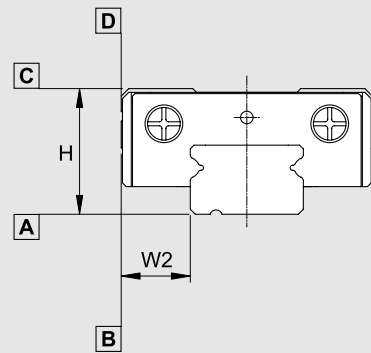

(Unit : mm)

Item	N	H	P
Tolerance for the height H	± 0.1	± 0.04	± 0.02
Tolerance for the rail-to-block lateral distance W2	± 0.1	± 0.04	± 0.02
Tolerance for the height H difference among blocks	0.03	0.015	0.007
Tolerance for rail-to-block lateral distance W2 distance among blocks	0.03	0.015	0.007
Running parallelism of surface C with surface A	C		
Running parallelism of surface D with surface B	D		

N : Normal H : High P : Precision

[Radial clearance]

(Unit : mm)

Reference	K1	K2
09	-2 ~ 2	-4 ~ 0
12	-2 ~ 2	-6 ~ 0
15	-2 ~ 2	-10 ~ 0

[Seal resistance]

(Unit : mm)

Reference	SBM/SBML	SBMW
09	0.2	0.8
12	0.59	1.1
15	1.18	1.3

[Grease]

SBM(L), SBMW Uses two types of grease according to working conditions. For details, please see the technical data for grease.

Shoulder height and fillet radius R

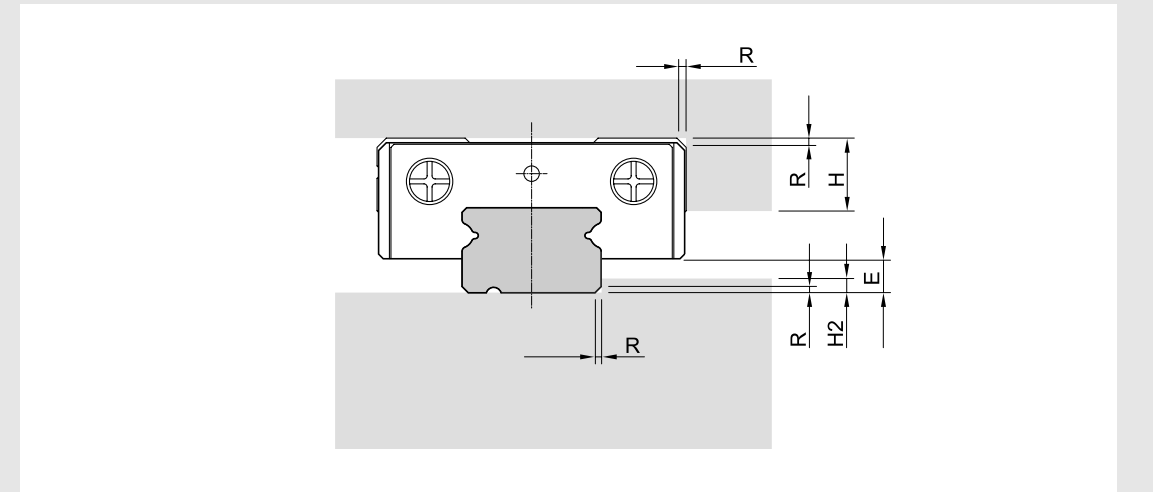

(Unit : mm)

Model number	Fillet radius R	Shoulders height H1	Shoulders height H2	E
SBM(L)09	0.3	3	1.9	2.2
SBM(L)12	0.3	4	2	3
SBM(L)15	0.3	5	2.5	4
SBMW09	0.3	3	3.4	3.7
SBMW12	0.3	4	3.7	4
SBMW15	0.3	5	3.4	3.7

Permissible tolerance (P) of parallelism

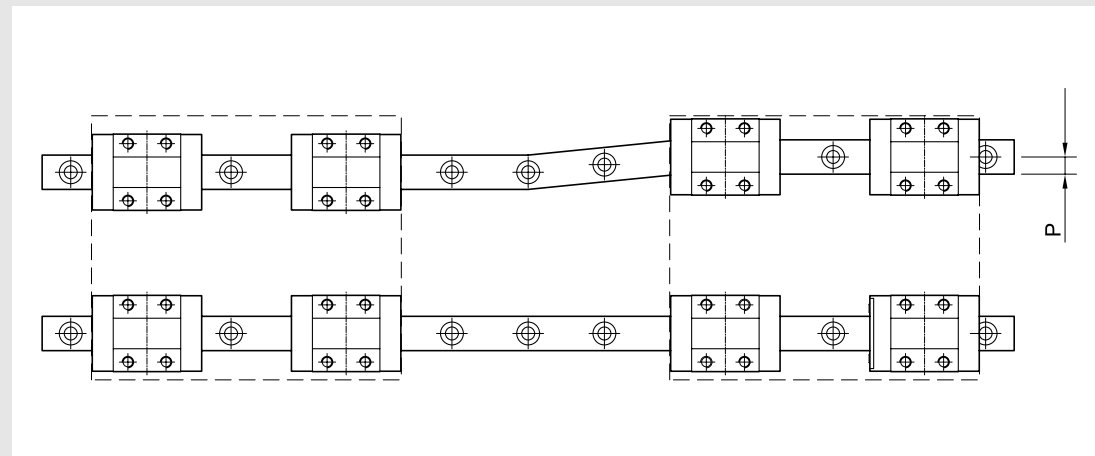

(Unit : mm)

Model size	K1	K2
09	3	4
12	5	9
15	6	10

Permissible tolerance (S) of two level offset

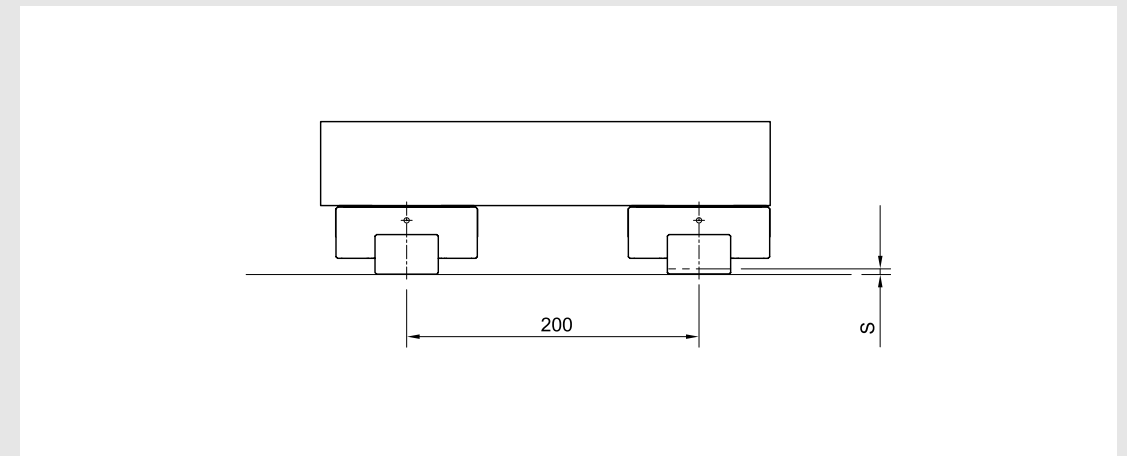

(Unit : mm)

Model size	K1	K2
09	6	35
12	12	50
15	20	60

Miniature Linear Rail System

Miniature Linear Rail System

Ordering example

[Seal resistance]

SBM09 - K1
[1] [2]

- [1] Model : SBM, SBML, SBMW
- [2] Preload : K1, K2

[Ordering example for rail]

SBM09 - 600L - B
[1] [2] [3]

- [1] Model : SBM, SBMW
- [2] Rail length
- [3] Through tap hole rail : Standard (No symbol)
If only rail is ordered, N grade is available.

[Ordering for assembled rail and block]

SBM09 - 2 - K1 - 600 - N - R - B - II
[1] [2] [3] [4] [5] [6] [7] [8]

- [1] Model : SBM, SBML, SBMW
- [2] Block quantity on rail
- [3] Preload : K1, K2
- [4] Rail length
- [5] Accuracy : N, H, P
- [6] Surface treatment
- [7] Through tap hole rail : Standard (No symbol)
- [8] Rail : Number of rails per axis 1=I, 2=II... 4=IV etc.

We recommend block and rail assembled to be ordered where high-precision and high-rigidity are required.

For surface treatment, please mark according to each surface treatment symbol.

If special G dimension is required, please mark when you place an order.

Standard and Max length

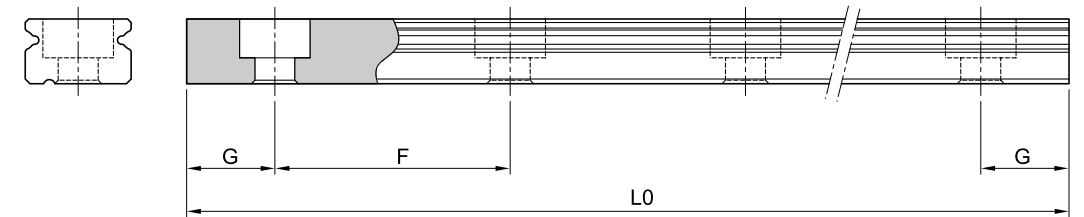

(Unit : mm)

Model number	SBM(L)09	SBM(L)12	SBM(L)15	SBMW09	SBMW12	SBMW15
Standard length	55	70	70	50	70	110
	75	95	110	80	110	150
	95	120	150	110	150	190
	115	145	190	140	190	230
	135	170	230	170	230	270
	155	195	270	200	270	350
	175	220	310	260	350	430
	215	245	350	320	430	510
	255	270	390	380	510	590
	295	320	430	440	590	670
	355	395	470	500	670	750
	415	470	590	560	750	830
	495	545	670	620	830	910
	535	620	830	680	910	990
	615	695	910	740	990	1070
	675	770	990	800	1070	1190
	715	870	1070	860	1190	
	735	970	1190	920		
	795	1020		980		
	875	1195		1040		
955			1100			
995			1190			
1035						
1115						
1195						
F	20	25	40	30	40	40
G	7.5	10	15	15	15	15
L0(Max length)	1195	1195	1190	1190	1190	1190

* SBM, SBML use same rail.

* If special G dimension is required, please mark when you place an order.

Miniature Linear Rail System

Miniature Linear Rail System

Miniature through tap hole rail

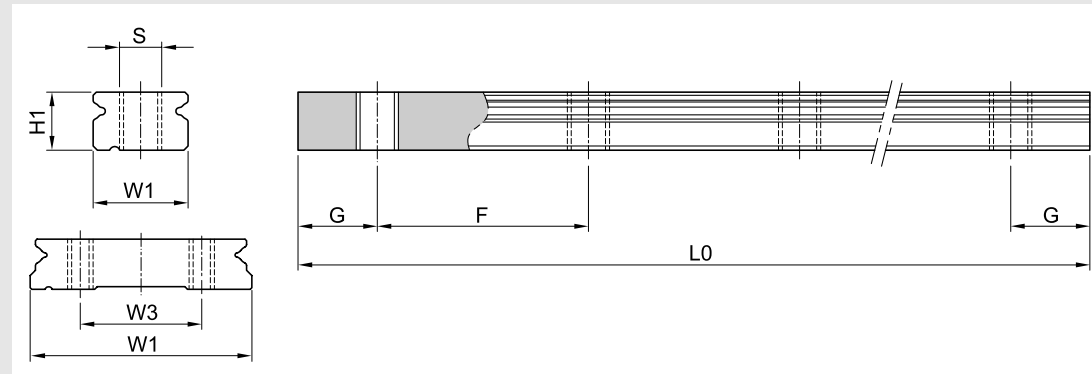

(Unit : mm)

Model	W1	W3	H1	S	G	F	L0 (Max length)	Mass (kg/m)
SBM 09-B	9	-	5.5	M4x0.7	7.5	20	1200	0.32
SBM 12-B	12	-	7.5	M4x0.7	10	25	1200	0.32
SBM 15-B	15	-	9.5	M4x0.7	15	40	1200	0.59
SBMW 09-B	18	-	7.5	M4x0.7	10	30	1200	0.99
SBMW 12-B	24	-	8.5	M5x0.8	15	40	1200	1.42
SBMW 15-B	42	23	9.5	M5x0.8	15	40	1200	2.93

Caution for mounting miniature through tap hole rail

If the mounting bolt is longer than overall mounting height, the bolt can protrude which can cause interference with the seal or bearing itself. Therefore, make sure the appropriate bolt selection.

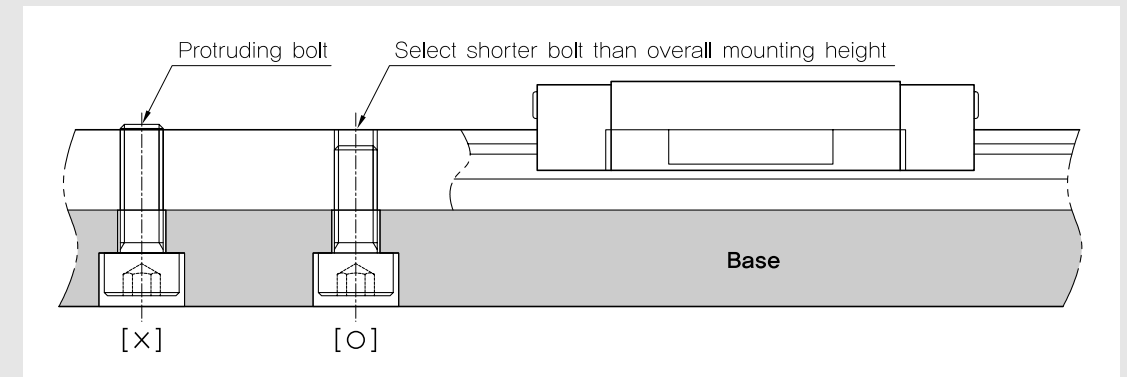

SBM/SBML

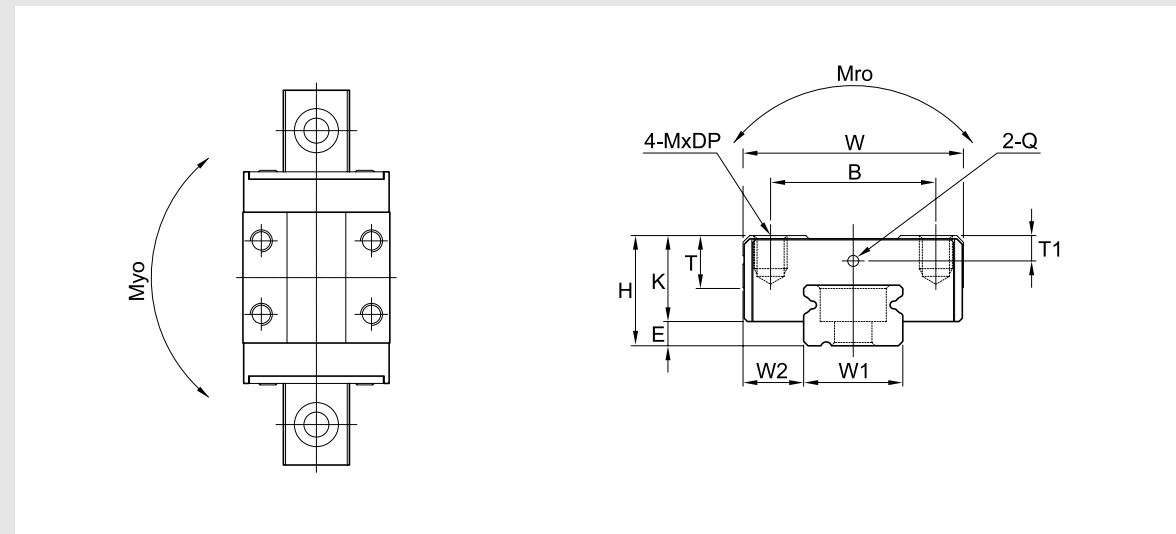

Model	Mounting dimension				Block dimensions									
	H	W	L	E	Mounting tap hole				L1	T	K	Greasing hole		
					B	J	M	DP				T1	Q	
SBM 09	10	20	30.4	2.2	15	10	M3	3	17.8	5	7.8	2.3	Ø1	
SBML 09	10	20	40.8	2.2	15	16	M3	3	28.2	5	7.8	2.3	Ø1	
SBM 12	13	27	35	3	20	15	M3	3.5	19.8	6	10	2.8	Ø1	
SBML 12	13	27	47.6	3	20	20	M3	3.5	32.6	6	10	2.8	Ø1	
SBM 15	16	32	43	4	25	20	M3	4	25.4	7	12	3.1	Ø1	
SBML 15	16	32	58.8	4	25	25	M3	4	41.2	7	12	3.1	Ø1	

C (Basic dynamic load rating), Co (Basic static load rating)

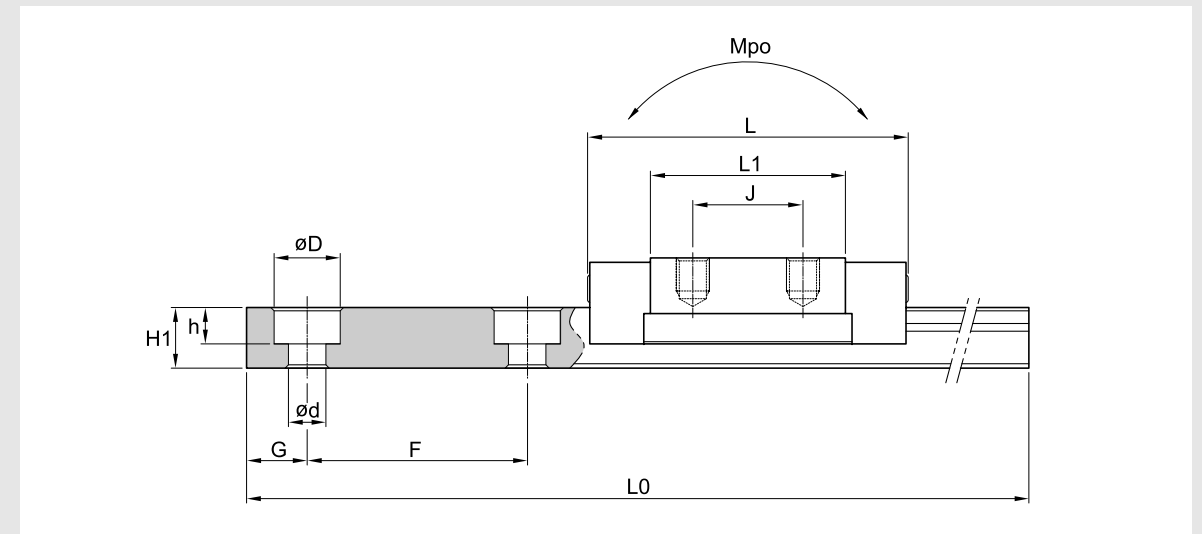

(Unit : mm)

Rail dimension										Basic load rating [kN]		Permissible static moment [kN·m]			Mass	
W1	W2	H1	F	Bolt hole			G	Max length of rail L0	C	Co	Mro	Mpo	Myo	Block [kg]	Rail [kg/m]	
				d	D	h										
9	5.5	5.5	20	3.5	6	3.3	7.5	1195	1.4	2.7	12.15	6.01	6.01	0.013	0.32	
9	5.5	5.5	20	3.5	6	3.3	7.5	1195	2.1	4.6	20.7	16.22	16.22	0.023	0.32	
12	7.5	7.5	25	3.5	6	4.5	10	1195	3.3	4.9	29.4	12.13	12.13	0.029	0.59	
12	7.5	7.5	25	3.5	6	4.5	10	1195	5	9.1	54.6	36.86	36.86	0.043	0.59	
15	9.5	9.5	40	3.5	6	4.5	15	1190	4.9	7.5	56.25	23.81	23.81	0.052	0.99	
15	9.5	9.5	40	3.5	6	4.5	15	1190	7.1	12.9	96.75	66.44	66.44	0.079	0.99	

SBMW

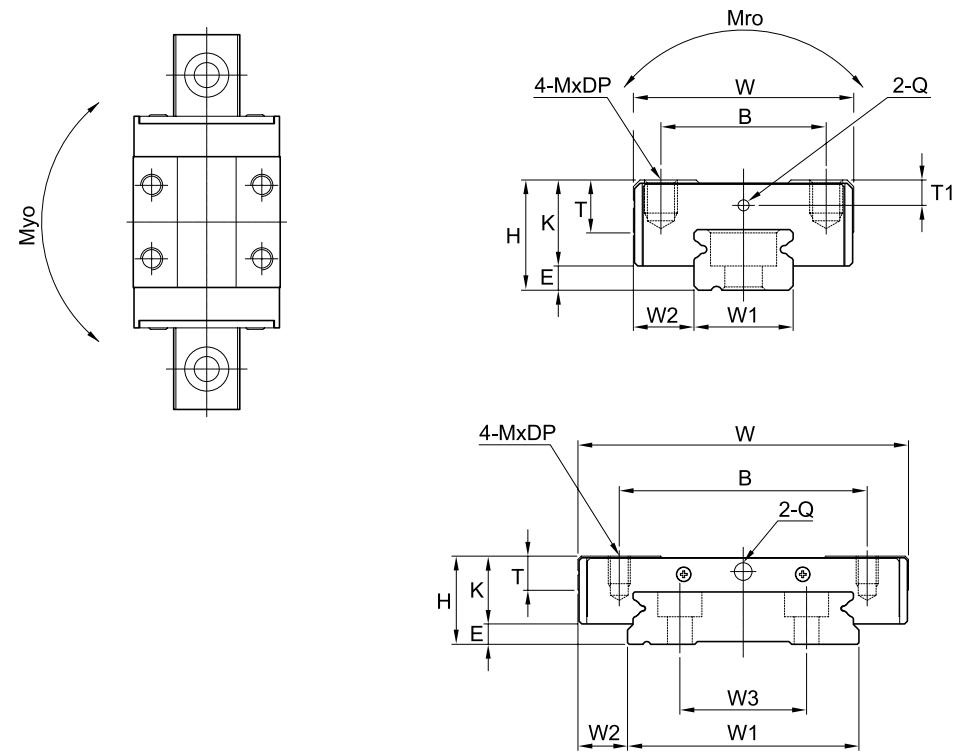

Model	Mounting dimension				Block dimensions									
	H	W	L	E	Mounting tap hole				L1	T	K	Greasing hole		
					B	J	M	DP				T1	Q	
SBMW 09	12	30	41	3.7	21	12	M3	3	27	4.5	8.3	2	Ø1.4	
SBMW 12	14	40	47.5	4	28	15	M3	3.5	30.9	5	10	2.4	Ø1.6	
SBMW 15	16	60	57.5	3.7	45	20	M3	4.5	38.9	6.2	12.3	2.8	Ø3.2	

C (Basic dynamic load rating), Co (Basic static load rating)

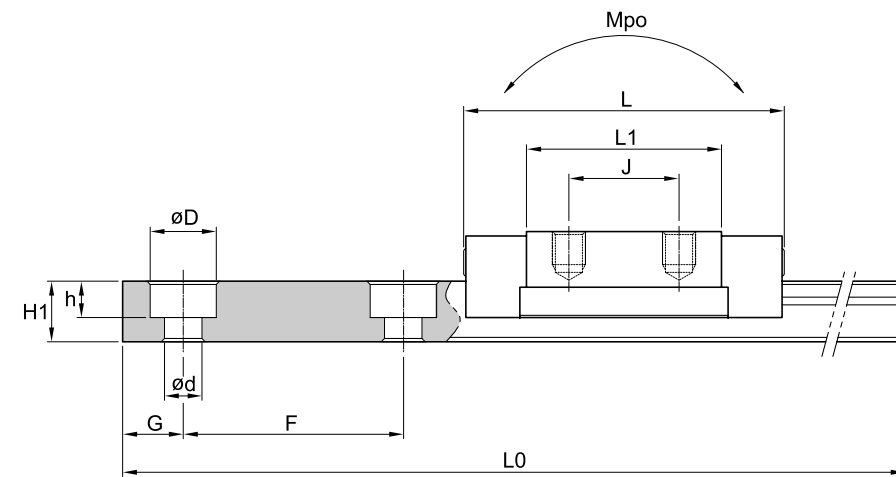

(Unit : mm)

Rail dimension										Basic load rating [kN]		Permissible static moment [kN•m]			Mass	
W1	W2	H1	W3	F	Bolt hole			G	Max length of rail L0	C	Co	Mro	Mpo	Myo	Block [kg]	Rail [kg/m]
					d	D	h									
18	6	7.5	-	30	3.5	6	3.5	10	1190	2.45	3.92	3.67	1.66	1.66	0.03	0.99
24	8	8.5	-	40	4.5	8	4.5	15	1190	4.02	6.08	4.86	1.75	1.9	0.03	1.42
42	9	9.5	23	40	4.5	8	4.5	15	1190	6.66	9.80	13.97	3.6	3.9	0.12	2.93