



Reliance[®]

Precision Mechatronics LLP

Precision Motion Control Components & Mechatronic Assemblies

Precision Couplings & Collars



Reliance Standard & Customised Components



Couplings & Collars

Associated Products



Quality system

Reliance operations are controlled by a quality management system approved to BS EN ISO 9001:2000.



Standard products and assemblies

Accurate positioning from modifiable standards for instrumentation, measurement and light actuation applications.



Bearings and spacers

A wide range of stainless steel, bronze and plastic bearings, stainless steel spacers and pre-loaded washers available.



Stepper motors

A range of stepper motors including the Reliance Cool Muscle all-in-one servo system. With a 32-bit RISC CPU intelligent driver, magnetic encoder and power management in one motor.



Linear products

Precision linear components which include leadscrews, slideways, linear bearings and shafting.





Product index

A general overview of Reliance's complete product range is available on the Reliance Precision Mechatronics LLP website at: www.rpmechatronics.co.uk



RoHS Compliant

All standard products within this brochure are RoHS compliant. For any further information, please go to our web site or contact a member of our sales team.

Standard Product Sales :  +44 (0)1484 601060  +44 (0)1484 601061
www.rpmechatronics.co.uk sales@rpmechatronics.co.uk

© Reliance Precision Mechatronics LLP



Page title	Page
Reliance couplings selection guide	2
Reli-a-Flex® couplings general overview	3
Reli-a-Flex® micro couplings.....	4
Reli-a-Flex® precision couplings	6
Reli-a-Flex® couplings with Reli-a-Grip™ clamp	8
Custom Reli-a-Flex® couplings.....	10
Stocked Reli-a-Flex® couplings	11
Bellows precision couplings.....	12
Oldham large offset couplings.....	14
Twin disc precision couplings	16
Solid couplings	18
Double wide clamp collars.....	19
Clamp collars.....	20
Threaded collars	21
Set screw collars	22
Application stories	23
Technical information	25
International sales representatives	29









Couplings & Collars

Selection Guide

The couplings featured in this brochure have been carefully selected to accommodate varying degrees of shaft misalignment whilst offering minimum distortion of rotation.

No one coupling provides a universal solution but the selection table below summarises the salient performance features for ease of comparison.

Full details for each coupling can be found on the product pages.

	Electrically insulating	Vibration damping	High reliability	No inherent backlash	Torque capacity	Misalignment capability	Low bearing load	Accuracy	Price / performance	
Std Option	✗	★ ★ ★ ★	★ ★ ★ ★	★ ★ ★ ★	★ ★ ★ ★	★ ★ ★ ★	★ ★ ★ ★	★ ★ ★ ★	★ ★ ★ ★	 <p>Reli-a-Flex® precision couplings</p> <ul style="list-style-type: none"> Outer diameters from ø6mm to ø25mm Bore diameters from ø1.5mm to ø12mm Custom designs available <p>Product information..... page 3</p>
	✗	✗	★ ★ ★ ★	★ ★ ★ ★	★ ★ ★ ★	★ ★ ★ ★	★ ★ ★ ★	★ ★ ★ ★	★ ★ ★ ★	 <p>Bellows precision couplings</p> <ul style="list-style-type: none"> Outer diameters from ø12mm to ø32mm Bore diameters from ø3mm to ø12mm <p>Product information page 12</p>
	★ ★ ★ ★	★ ★	✗	★ ★ ★ ★	★ ★ ★ ★	★ ★ ★ ★	★ ★ ★ ★	★ ★ ★ ★	★ ★ ★ ★	 <p>Oldham large offset couplings</p> <ul style="list-style-type: none"> Outer diameters from ø13mm to ø41mm Bore diameters from ø3mm to ø12mm <p>Product information..... page 14</p>
	✗	✗	★ ★ ★ ★	★ ★ ★ ★	★ ★ ★ ★	★ ★ ★ ★	★ ★ ★ ★	★ ★ ★ ★	★ ★ ★ ★	 <p>Twin disc precision couplings</p> <ul style="list-style-type: none"> Outer diameters from ø19mm to ø32mm Bore diameters from ø5mm to ø12mm <p>Product information..... page 16</p>
	✗	✗	★ ★ ★ ★	★ ★ ★ ★	✗	★ ★ ★ ★	★ ★ ★ ★	★ ★ ★ ★	★ ★ ★ ★	 <p>Solid precision couplings</p> <ul style="list-style-type: none"> Outer diameters from ø15mm to ø29mm Bore diameters from ø3mm to ø10mm <p>Product information..... page 18</p>
<p>Comparative star rating:</p> <p>★★★★ best</p> <p>★ worst</p> <p>✗ not applicable</p>										 <p>Engineering information</p> <p>Definition of terms used</p> <ul style="list-style-type: none"> Shaft misalignment Transmission error <p>Technical information page 25</p>

www.rpmechatronics.co.uk







The Reli-a-Flex® coupling, specifically designed and manufactured by Reliance to:

- Improve system accuracy**
 The Reli-a-Flex® coupling provides excellent kinematic transfer of motion with high torsional stiffness, zero backlash and constant velocity.
- Extend system life**
 The Reli-a-Flex® coupling introduces negligible radial and axial bearing loads, extending system life.

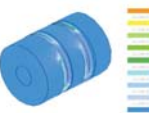

Reli-a-Flex® flexible shaft couplings, the range:

	<p>Short or Long</p>	<ul style="list-style-type: none"> RCS type (short) where space is limited. RCL type (long) where greater parallel offset and greater accuracy are required.
	<p>Reli-a-Grip™</p>	<ul style="list-style-type: none"> The Reli-a-Grip™ clamp enables Reli-a-Flex® coupling to be used to its full potential. Greater torques can be transmitted without the need to use set screws, which can potentially damage the shaft.
	<p>Precision or Micro</p>	<ul style="list-style-type: none"> Precision coupling with outer diameters from 13 to 25mm. Micro coupling with outer diameters from 6 to 10mm.
	<p>Clamp or Set screw</p>	<ul style="list-style-type: none"> Clamp type leaves shafts unmarked. Set screw type where higher speeds are required. <p style="text-align: right;">Please enquire</p>
	<p>Electrically insulated</p>	<ul style="list-style-type: none"> Protects delicate instruments from powered drive. Available with selected bores on RCL type aluminium couplings, sizes 20 and 25. <p style="text-align: right;">Please enquire</p>
	<p>Custom designs</p>	<ul style="list-style-type: none"> Predictable performances. Available with outer diameters from 6 to 40mm. Alternative materials may be specified. <p style="text-align: right;">Please enquire</p>

www.rpmechatronics.co.uk



Micro Reli-a-Flex® Couplings

1.5 - 5mm Bore

General Information

All dimensions in mm
 General tolerances:
 ±0.13mm
 Material:
 Aluminium alloy
 Grade 7075-T6
 Alocrom 1000(1)

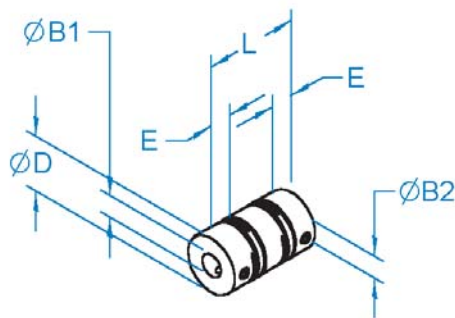

RCL (long type) **RCS** (short type)

Notes

(1): Bores may be left unalocromed

Couplings are chambered for ease of assembly and fitted with stainless steel screws.

Part number selection table

Example Part No:- RCS A 8 - 4-2				Dimensions (mm)																
Basic Part No.	Material	Size	Standard Bore Sizes ØB1 and ØB2 (bore tolerance +0.010/-0.000)			O/D ØD	Length L	Hub Length E	Fitted Screw											
			1.5	2	3	4	5	6.0	8.0	10.0	9.35	11.70	13.65	2.80	3.20	4.00	M1.2*	M1.6	M2	
RCS (short)	A	6																		
		8																		
		10																		
RCL (long)	A	6																		
		8																		
		10																		

Maximum shaft intrusion when fitted = E+2mm.

* Coupling fitted with slotted head set screws.

Patented

UK Number 2316735
 US Number 6,203,437 B1
 European Number EP 0922168 B1
 Japanese Pending No.511360/1998

Associated Products

Shafts
 Bearings
 Leadscrews
 Stepper motors

Visit our online catalogue for associated products

www.rpmechatronics.co.uk

Non-standard options, please enquire...

- Non-standard bore sizes, including imperial.
- Alternative materials.
- Custom designs.
- For in stock items and custom designs refer to pages 10-11 custom.



Standard Product Sales : ☎ +44 (0)1484 601060 📠 +44 (0)1484 601061
 www.rpmechatronics.co.uk sales@rpmechatronics.co.uk

© Reliance Precision Mechatronics LLP



Technical specifications

Basic Part No.	Material	Size	Torsional Stiffness mNm/arcmin	Radial Compliance microns/N	Misalignment			Max Inertia g.cm ²	Max Mass g
					Parallel mm	Angular deg	Axial mm		
RCS (short)	A	6	1.22	21.0	0.020	1.7	±0.06	0.03	0.65
		8	2.53	35.0	0.050	2.0	±0.10	0.11	1.30
		10	4.89	28.0	0.060	2.0	±0.17	0.33	2.30
RCL (long)	A	6	1.25	79.0	0.040	1.7	±0.06	0.05	0.95
		8	2.53	102.0	0.100	2.0	±0.10	0.15	1.70
		10	4.89	83.0	0.120	2.0	±0.17	0.43	3.00

Specifications vary according to bore size. For exact figures, please enquire.

General Information

All dimensions in mm
 General tolerances: ±0.13mm
 Material:
 Aluminium alloy
 Grade 7075-T6
 Alocrom 1000(1)

Notes

(2): Bores may be left unalocromed

Torque and speed capacity

Basic Part No.	Material	Size	Typical Torque Capacity			Max Speed rpm
			Reversing Nm	Non Reversing Nm	Peak Nm	
RCS (short)	A	6	0.10	0.15	0.25	70000
		8	0.20	0.30	0.50	40000
		10	0.30	0.45	0.75	35000
RCL (long)	A	6	0.10	0.15	0.25	32000
		8	0.20	0.30	0.50	24000
		10	0.30	0.45	0.75	22000

Specifications vary according to bore size. For exact figures, please enquire.

Patented

UK Number 2316735
 US Number 6,203,437 B1
 European Number EP 0922168 B1
 Japanese Pending No.511360/1998

Associated Products

Shafts
 Bearings
 Leadscrews
 Stepper motors

Visit our online catalogue for associated products

Technical features - Apply to the whole Reli-a-Flex® coupling range

- Zero backlash, reliable one-piece construction.
- Unique design maximises torsional stiffness without inducing high bearing loads.
- Minimal velocity and positional fluctuations.
- Over 50,000,000 test cycles at rated load and 80% offset without failure.
- Maintenance free.
- Recommended temperature range -80°C to +80°C.



www.rpmechatronics.co.uk



Reli-a-Flex® Precision Couplings

3 - 12mm Bore

General Information

All dimensions in mm
 General tolerances:
 ±0.13mm
 Material:
 Aluminium alloy
 Grade 7075-T6
 Alocrom 1000⁽¹⁾

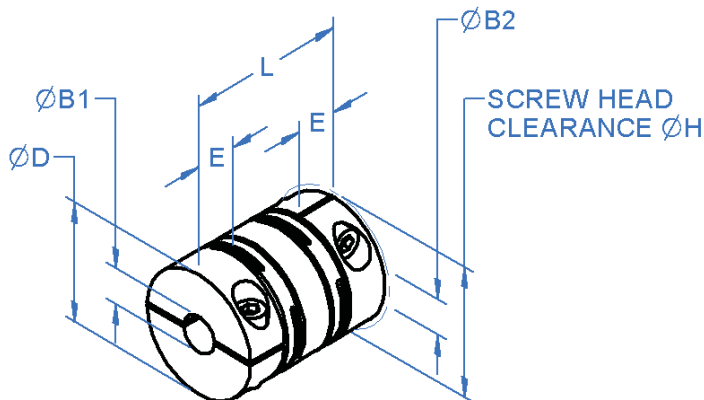

RCL (long type) **RCS** (short type)

Couplings are chambered for ease of assembly and fitted with stainless steel screws.

Notes

⁽¹⁾: Bores may be left unalocromed

Part number selection table

Example Part No:- RCS A 20C - 8-5				Dimensions (mm)				
Basic Part No.	Material	Size	Standard Bore Sizes ØB1 and ØB2 (bore tolerance +0.020/-0.000)	O/D		Length L	Hub Length E	Fitted Screw
				ØD	ØH			
RCS (short)	A	13C	3 4 5 6	13.0	14.5	16.80	5.00	M1.6
		16C	3 4 5 6 8	16.0	18.0	19.75	5.90	M2
		20C	4 5 6 8 10	20.0	21.8	21.50	6.60	M2.5
		25C	5 6 8 10 12	25.0	26.9	25.80	7.60	M3
RCL (long)	A	13C	3 4 5 6	13.0	14.5	20.00	5.00	M1.6
		16C	3 4 5 6 8	16.0	18.0	23.50	5.90	M2
		20C	4 5 6 8 10	20.0	21.8	26.00	6.60	M2.5
		25C	5 6 8 10 12	25.0	26.9	34.00	7.60	M3

Maximum shaft intrusion when fitted = E+2mm.

Patented

UK Number 2316735
 US Number 6,203,437 B1
 European Number EP 0922168 B1
 Japanese Pending No.511360/1998

Associated Products

Shafts
 Bearings
 Leadscrews
 Stepper motors

Visit our online catalogue for associated products

Non-standard options, please enquire....

- Electrically insulated, sizes 20 and 25.
- Set screw fixing.
- Non-standard bore sizes, including imperial.
- Alternative materials.
- Custom designs.
- Reli-a-Grip™ clamp design - see pages 8 - 9.
- For in stock items and custom designs refer to pages 10-11 custom.



Standard Product Sales : ☎ +44 (0)1484 601060 📠 +44 (0)1484 601061
www.rpmechatronics.co.uk sales@rpmechatronics.co.uk

© Reliance Precision Mechatronics LLP



Technical specifications

Basic Part No.	Material	Size	Torsional Stiffness mNm/arcmin	Radial Compliance microns/N	Misalignment			Max Inertia g.cm ²	Max Mass g
					Parallel mm	Angular deg	Axial mm		
RCS (short)	A	13C	13.09	29.2	0.08	2.5	±0.30	1.0	4.4
		16C	20.36	28.9	0.10	2.5	±0.40	2.9	8.6
		20C	33.45	23.4	0.12	3.0	±0.50	7.9	14.9
		25C	52.94	20.0	0.16	3.0	±0.70	23.0	27.5
RCL (long)	A	13C	15.56	64.3	0.15	2.5	±0.30	1.2	5.5
		16C	24.43	65.1	0.20	2.5	±0.40	3.3	10.6
		20C	40.43	62.0	0.25	3.0	±0.50	9.0	18.7
		25C	66.03	82.2	0.40	3.0	±0.70	31.0	38.5

Specifications vary according to bore size. For exact figures, please enquire.

General Information

All dimensions in mm
 General tolerances:
 ±0.13mm
 Material:
 Aluminium alloy
 Grade 7075-T6
 Alocrom 1000⁽¹⁾

Notes

(1): Bores may be left unalocromed

Patented

UK Number 2316735
 US Number 6,203,437 B1
 European Number EP 0922168 B1
 Japanese Pending No.511360/1998

Associated Products

Shafts
 Bearings
 Leadscrews
 Stepper motors

Visit our online catalogue for associated products

Torque and speed capacity

Basic Part No.	Material	Size	Typical Torque Capacity			Max Speed* rpm
			Reversing Nm	Non Reversing Nm	Peak Nm	
RCS (short) or RCL (long)	A	13C	0.35	0.45	0.50	12000
		16C	0.55	0.85	1.25	10000
		20C	0.95	1.45	2.45	7500
		25C	1.55	2.35	3.90	5000

* For set screw coupling, increase speed by 150% on short type (RCS) and by 66% on long type (RCL)

Specifications vary according to bore size. For exact figures, please enquire.





Reli-a-Flex® Precision Couplings with Reli-a-Grip™ Clamp

3 - 12mm Bore

General Information

All dimensions in mm
General tolerances:
±0.13mm
Material:
Aluminium alloy
Grade 7075-T6
Alocrom 1000⁽¹⁾

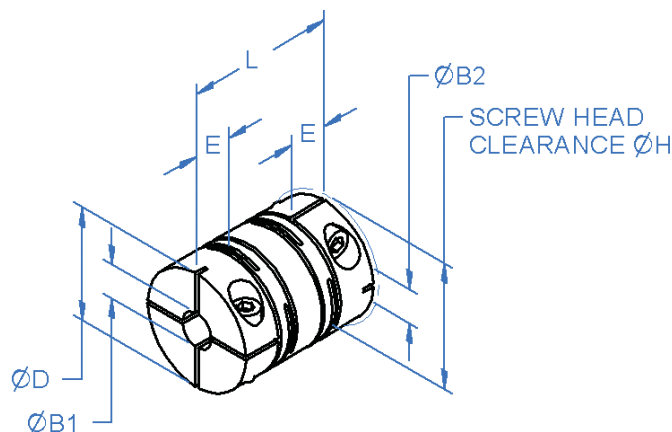

RCL (long type) **RCS** (short type)

Notes

(1): Bores may be left unalocromed

Couplings are chambered for ease of assembly and fitted with stainless steel screws.

Part number selection table

Example Part No:- RCS A 20G - 8-5				Dimensions (mm)				
Basic Part No.	Material	Size	Standard Bore Sizes ØB1 and ØB2 (bore tolerance +0.020/-0.000)	O/D		Length	Hub Length	Fitted Screw
				ØD	ØH	L	E	
RCS (short)	A	13G	3 4 5 6	13.0	14.5	16.80	5.00	M1.6
		16G	3 4 5 6 8	16.0	18.0	19.75	5.90	M2
		20G	4 5 6 8 10	20.0	21.8	21.50	6.60	M2.5
		25G	5 6 8 10 12	25.0	26.9	25.80	7.60	M3
RCL (long)	A	13G	3 4 5 6	13.0	14.5	20.00	5.00	M1.6
		16G	3 4 5 6 8	16.0	18.0	23.50	5.90	M2
		20G	4 5 6 8 10	20.0	21.8	26.00	6.60	M2.5
		25G	5 6 8 10 12	25.0	26.9	34.00	7.60	M3

Maximum shaft intrusion when fitted = E+2mm.

Patented

UK Number 2316735
US Number 6,203,437 B1
European Number EP 0922168 B1
Japanese Pending No.511360/1998

Associated Products

Shafts
Bearings
Leadscrews
Stepper motors

Visit our online catalogue for associated products

Non-standard options, please enquire...

- Electrically insulated.
- Non-standard bore sizes, including imperial.
- Alternative materials.
- Custom designs.





Technical specifications

Basic Part No.	Material	Size	Torsional Stiffness mNm/arcmin	Radial Compliance microns/N	Misalignment			Max Inertia g.cm ²	Max Mass g
					Parallel mm	Angular deg	Axial mm		
RCS (short)	A	13G	13.09	29.2	0.08	2.5	±0.30	1.0	4.4
		16G	20.36	28.9	0.10	2.5	±0.40	2.9	8.6
		20G	33.45	23.4	0.12	3.0	±0.50	7.9	14.9
		25G	52.94	20.0	0.16	3.0	±0.70	23.0	27.5
RCL (long)	A	13G	15.56	64.3	0.15	2.5	±0.30	1.2	5.5
		16G	24.43	65.1	0.20	2.5	±0.40	3.3	10.6
		20G	40.43	62.0	0.25	3.0	±0.50	9.0	18.7
		25G	66.03	82.2	0.40	3.0	±0.70	31.0	38.5

Specifications vary according to bore size. For exact figures, please enquire.

General Information

All dimensions in mm
General tolerances:
±0.13mm
Material:
Aluminium alloy
Grade 7075-T6
Alocrom 1000⁽¹⁾

Notes

(1): Bores may be left unalocromed

Patented

UK Number 2316735
US Number 6,203,437 B1
European Number EP 0922168 B1
Japanese Pending No.511360/1998

Associated Products

Shafts
Bearings
Leadscrews
Stepper motors

Visit our online catalogue for associated products

Torque and speed capacity

Basic Part No.	Material	Size	Typical Torque Capacity			Max Speed rpm
			Reversing Nm	Non Reversing Nm	Peak Nm	
RCS (short) or RCL (long)	A	13G	0.45	0.60	0.70	12000
		16G	0.75	1.15	1.65	10000
		20G	1.30	1.95	3.25	7500
		25G	2.05	3.10	5.20	5000

Specifications vary according to bore size. For exact figures, please enquire.





Reli-a-Flex® Precision Couplings

Custom Designs



One off custom designs....

- The flexible manufacturing of the Reli-a-Flex® allows for effective customisation of the coupling to suit your specific application.
- Special interfaces can be incorporated into your design to allow easier interaction between the coupling and other components within your assembly.
- Alternative materials such as PEEK™ polymer and other plastics are available.
- Reliance engineers can confidently predict the performance which will be achieved by the Reli-a-Flex® special when provided with details of the allowable space envelope. Please refer to diagram below

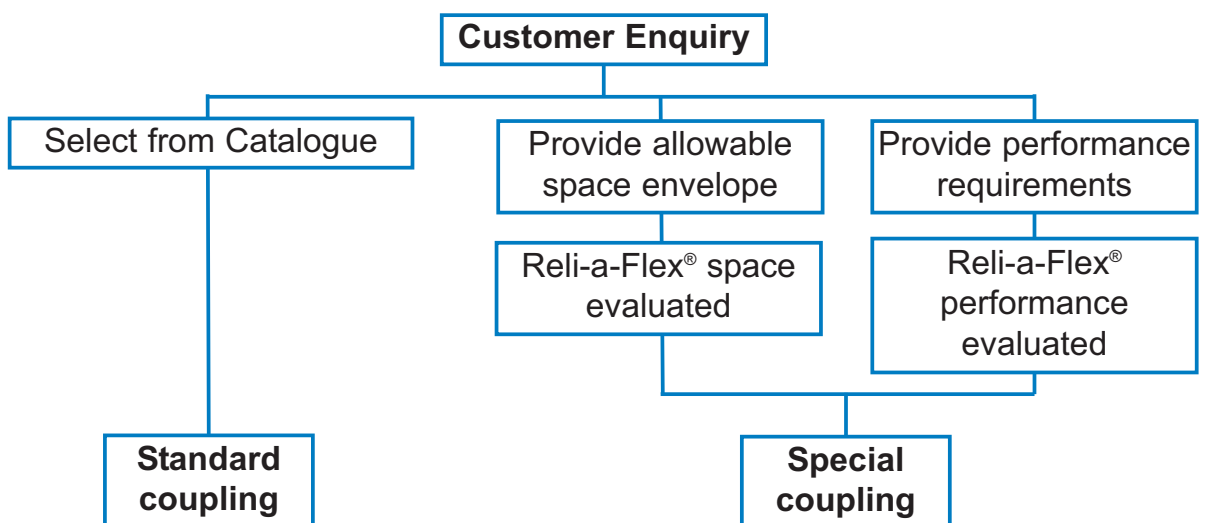



Preferred range of Reli-a-Flex® couplings

Standard couplings in-stock and available on short delivery at reduced prices.

Visit our website at www.rpmechatronics.co.uk for the latest details regarding this range.

Long type	Short type
<u>Size 6</u> RCLA6-1.5-1.5 RCLA6-3-1.5	<u>Size 6</u> RCSA6-1.5-1.5 RCSA6-3-1.5
<u>Size 8</u> RCLA8-2-2 RCLA8-3-3	<u>Size 8</u> RCSA8-2-2 RCSA8-3-3
<u>Size 10</u> RCLA10-5-3	<u>Size 10</u> RCSA10-5-3
<u>Size 13</u> RCLA13C-3-3 RCLA13C-5-5 RCLA13C-0.250-5	<u>Size 13</u> RCSA13C-3-3 RCSA13C-5-5 RCSA13C-0.250-5
<u>Size 16</u> RCLA16C-6-5 RCLA16C-6-6 RCLA16C-0.250-5 RCLA16C-0.250-6	<u>Size 16</u> RCSA16C-6-5 RCSA16C-6-6 RCSA16C-0.250-5 RCSA16C-0.250-6
<u>Size 20</u> RCLA20C-6-5 RCLA20C-6-6 RCLA20C-0.250-5 RCLA20C-0.250-6	<u>Size 20</u> RCSA20C-6-5 RCSA20C-6-6 RCSA20C-0.250-5 RCSA20C-0.250-6
<u>Size 25</u> RCLA25C-0.375-6 RCLA25C-10-0.375 RCLA25C-10-10 RCLA25C-10-6 RCLA25C-12-0.375 RCLA25C-12-10	<u>Size 25</u> RCSA25C-0.375-6 RCSA25C-10-0.375 RCSA25C-10-10 RCSA25C-10-6 RCSA25C-12-0.375 RCSA25C-12-10



Bellows Precision Couplings

3 - 12mm Bore

General Information

All dimensions in mm
 General tolerances:
 ±0.4mm
 Material:
 End pieces
 Anodised aluminium
 Bellows
 Phosphor bronze
 or
 All stainless steel

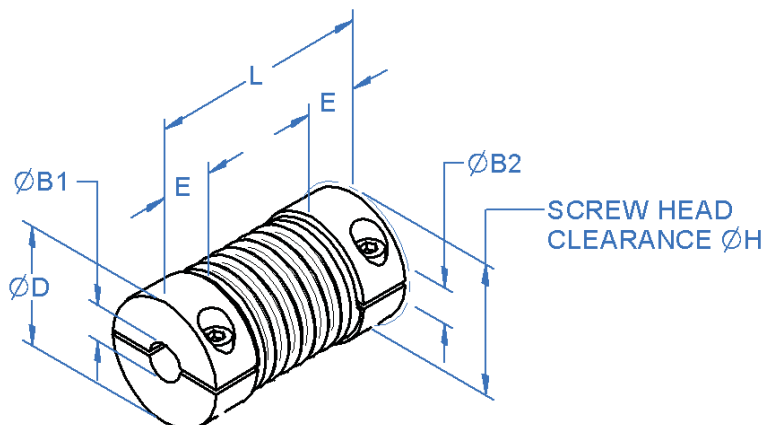

Phosphor bronze couplings fitted with alloy steel screws, black oiled as standard.
 Stainless steel couplings fitted with stainless steel screws as standard.

Associated Products

Shafts
 Bearings
 Leadscrews

Visit our online catalogue for associated products

Part number selection table

Example Part No:- RFB S 20C - 8-6				Dimensions (mm)				
Basic Part No.	Material	Size	Standard Bore Sizes ØB1 and ØB2 (bore tolerance H8)	O/D ØD	ØH*	Length L	Hub Length E	Fitted Screw *
RFB	B (Ph. bronze)	12C	3‡ 4 5 6‡	12.0	14.0	23.5	7.5	M2
		16C	4‡ 5 6 8‡	16.0	17.3	26.5	9.0	M2.5
	S (St. steel)	20C	5‡ 6 8 10‡	20.0	20.0	32.0	10.0	M2.5
		25C	6‡ 8 10 12‡	25.0	25.7	36.5	12.0	M3
		32C	6‡ 8 10 12	32.0	33.2	42.0	13.5	M4

Imperial bores (1/4" to 3/8") available, please enquire.

‡ Bore size only available on set screw type (remove C from part no.)

* Figures not valid for set screw type, please enquire.

Non-standard options, please enquire....

- Non-standard bore sizes, including imperial.
- Custom designs.





Technical specifications

Basic Part No.	Material	Size	Torsional Stiffness mNm/arcmin	Misalignment			Max Inertia * g.cm ²	Max Mass * g
				Parallel mm	Angular deg	Axial mm		
RFB	B	12C	23.85	0.10	1.5	+0.4/-1.2	1.0	4.1
		16C	32.00	0.10	1.5	+0.4/-1.2	3.7	10.4
		20C	52.36	0.15	2.0	+0.6/-1.8	10.0	17.2
		25C	69.81	0.15	2.0	+0.6/-1.8	31.0	33.8
		32C	95.99	0.20	2.0	+0.8/-2.5	98.0	65.6
	S	12C	29.09	0.10	1.5	+0.4/-1.2	2.1	10.0
		16C	43.63	0.10	1.5	+0.4/-1.2	8.2	23.7
		20C	64.00	0.15	2.0	+0.6/-1.8	23.0	41.4
		25C	95.99	0.15	2.0	+0.6/-1.8	70.0	79.3
		32C	142.54	0.20	2.0	+0.8/-2.5	220.0	151.8

Misalignments of 1/3 of those shown will extend the life of the coupling.

* Figures not valid for set screw type, please enquire.

General Information

All dimensions in mm
 General tolerances:
 ±0.4mm
 Material:
 End pieces
 Anodised aluminium
 Bellows
 Phosphor bronze
 or
 All stainless steel

Associated Products

Shafts
 Bearings
 Leadscrews

Visit our online catalogue for associated products

Torque and speed capacity

Basic Part No.	Material	Size	Torque Capacity		Max Speed * rpm
			Rated Nm	Peak Nm	
RFB	B	12C	0.30	0.60	13000
		16C	0.50	1.00	9500
		20C	0.80	1.60	7700
		25C	1.30	2.60	6100
		32C	2.00	4.00	4800
	S	12C	0.50	1.00	13000
		16C	1.00	2.00	9500
		20C	1.50	3.00	7700
		25C	2.00	4.00	6100
		32C	3.00	6.00	4800

* For set screw coupling, increase speed by 145%.

Technical features

- Zero backlash.
- High torsional stiffness and low bearing loads.
- Complete absorption of eccentricity, angularity and end play by spring action of the bellows.
- Maintenance free.
- Recommended temperature range 0°C to +90°C.



www.rpmechatronics.co.uk

Standard Product Sales : ☎ +44 (0)1484 601060 📠 +44 (0)1484 601061
www.rpmechatronics.co.uk sales@rpmechatronics.co.uk

© Reliance Precision Mechatronics LLP



Oldham Large Offset Couplings

3 - 12mm Bore

General Information

All dimensions in mm
 Manufactured by
 Ruland Corp
 Hub material:
 Aluminium bar 2024
 T351 or 7075 T651
 type II sulfuric
 anodised
 Spacer material:
 Acetal and nylon 11

Associated Products

Shafts
 Bearings
 Leadscrews

Visit our online catalogue for associated products

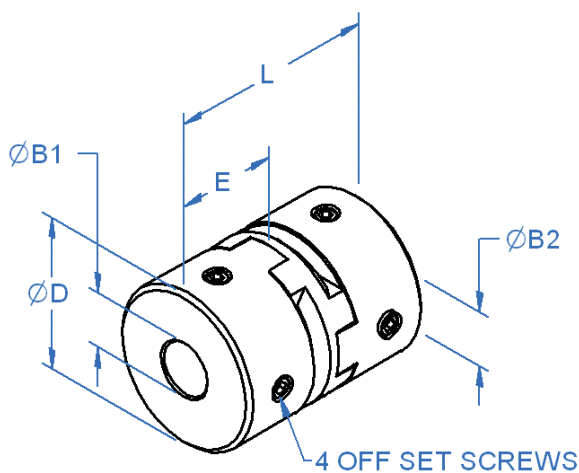

MOST (set screw)

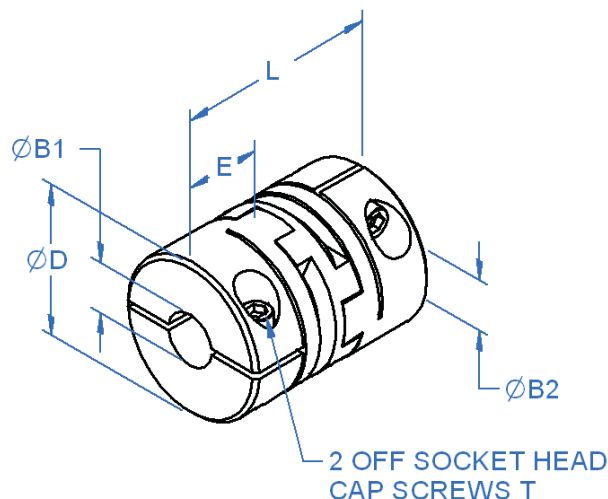

MOCT (clamp)

Part number selection table

Example Part No:- MOST AT-13-3-3							Dimensions (mm)						
Basic Part No.	Disc Material	Size	Standard Bore Sizes ØB1 and ØB2				O/D ØD	Length L	Hub Length E	Fitted Screw T			
			(bore tolerance +0.020/-0.000)										
MOST (set screw)	AT (Acetal)	13	3	4	5	6	12.7	15.9	5.6	M3			
		19	4	5	6	8	19.1	22.2	7.6	M3			
	NL (Nylon)	25				6	8	10	12	25.4	28.6	9.9	M4
		33					8	10	12	33.3	47.6	15.0	M4
		41						10	12	41.3	50.8	18.0	M5
MOCT (clamp)	AT (Acetal)	19		4	5					19.1	25.4	9.7	M2.5
		25		4	5	6	8	10	12	25.4	31.8	11.9	M3
	NL (Nylon)	33				6	8	10	12	33.3	47.6	15.0	M3
		41					8	10	12	41.3	50.8	18.0	M4

Imperial bores (1/8" to 1/2") available, please enquire.

www.rpmechatronics.co.uk

Non-standard options, please enquire....

- Non-standard bore sizes, including imperial.



Standard Product Sales : ☎ +44 (0)1484 601060 📠 +44 (0)1484 601061
 www.rpmechatronics.co.uk sales@rpmechatronics.co.uk

© Reliance Precision Mechatronics LLP



Technical specifications

Size	Disc Material	Torsional Stiffness Deg/Nm	Rated Torque Nm	Break Torque Nm	Parallel Misalignment mm	Axial Motion mm
13	AT	0.636	0.68	3.9	0.10	0.05
	NL	2.560	0.17	2.8	0.10	0.05
19	AT	0.380	2.25	10.5	0.20	0.10
	NL	1.240	0.57	9.6	0.20	0.10
25	AT	0.291	4.75	19.0	0.20	0.10
	NL	1.110	1.13	15.9	0.20	0.10
33	AT	0.079	8.00	39.5	0.20	0.15
	NL	0.460	2.05	34.0	0.20	0.15
41	AT	0.068	14.75	54.5	0.25	0.15
	NL	0.330	3.65	45.3	0.25	0.15

General Information

All dimensions in mm
 Manufactured by
 Ruland Corp
 Hub material:
 Aluminium bar 2024
 T351 or 7075 T651
 type II sulfuric
 anodised
 Spacer material:
 Acetal and nylon 11

Associated Products

Shafts
 Bearings
 Leadscrews

Visit our online catalogue for associated products

Technical features

- Zero backlash on acetal disc.
- High parallel misalignment capability up to 0.5mm.
- Electrically insulated discs act as a mechanical fuse preventing damage to other components.
- Temperature range:-
 acetal disc: -23°C to +65°C.
 nylon disc: -23°C to +54°C.
- Max speed: 4,500rpm.

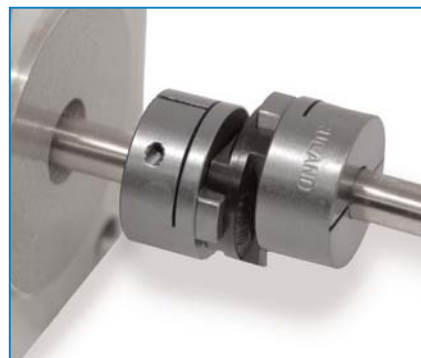

www.rpmechatronics.co.uk



Twin Disc Precision Couplings

5 - 12mm Bore

General Information

All dimensions in mm
 General tolerances:
 ±0.4mm
 Material:
 Disc and pins
 Stainless steel.
 End pieces centre
 spacers
 Anodised aluminium.

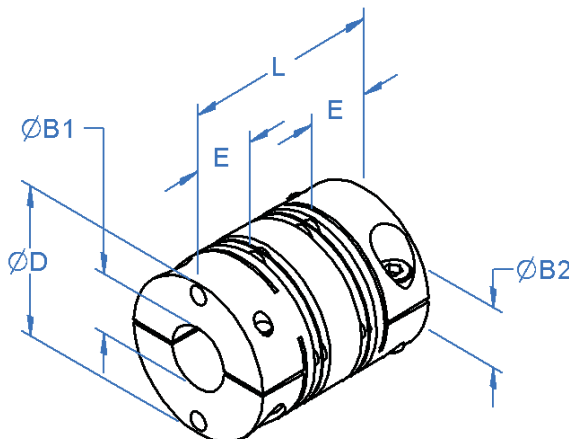

Twin disc couplings fitted with alloy steel screws, black oiled as standard.

Associated Products

Shafts
 Encoders

Visit our online catalogue for associated products

Part number selection table

Example Part No:- RDW 19C - 8-5			Dimensions (mm)			
Basic Part No.	Size	Standard Bore Sizes ØB1 and ØB2 (bore tolerance +0.010/-0.000)	O/D ØD	Length L	Hub Length E	Fitted Screw
RDW	19C	5 6 8	19.0	27.0	8.0	M2
	25C	6 8 10 12	25.0	31.0	10.0	M2.5
	32C	8 10 12	32.0	40.0	12.0	M3

Imperial bores (1/4" to 3/8") available, please enquire.

Non-standard options, please enquire...

- Non-standard bore sizes, including imperial.
- Set screw clamping.
- Stainless steel screws.



www.rpmechatronics.co.uk

Standard Product Sales : ☎ +44 (0)1484 601060 📠 +44 (0)1484 601061
www.rpmechatronics.co.uk sales@rpmechatronics.co.uk

© Reliance Precision Mechatronics LLP



Technical specifications

Basic Part No.	Size	Torsional Stiffness mNm/arcmin	Misalignment			Max Inertia g.cm ²	Max Mass g
			Parallel mm	Angular deg	Axial mm		
RDW	19C	58.18	0.12	1.5	±0.5	8.8	19
	25C	130.90	0.12			28.0	30
	32C	319.98	0.15			99.0	68

Misalignments of 1/3 of those shown will extend the life of the coupling.

General Information

All dimensions in mm
General tolerances:
±0.4mm

Material:
Disc and pins
Stainless steel.
End pieces centre
spacers
Anodised aluminium.

Associated Products

Shafts
Encoders

Visit our online
catalogue for
associated products

Torque and speed capacity

Basic Part No.	Size	Torque Capacity		Max Speed rpm
		Rated Nm	Peak Nm	
RDW	19C	0.70	1.50	10000
	25C	1.00	2.00	8000
	32C	2.50	5.00	6000

Technical features

- Zero backlash.
- High torsional stiffness.
- Complete absorption of eccentricity and angularity by spring action of the discs.
- Maintenance free.
- Recommended temperature range ambient.





Solid Couplings

3-10mm Bore

General Information

All dimensions in mm
 Manufactured by
 Ruland Corp
 Material:
 Aluminium alloy
 grade 2024.T351
 Stainless steel
 grade 18.8 type 303

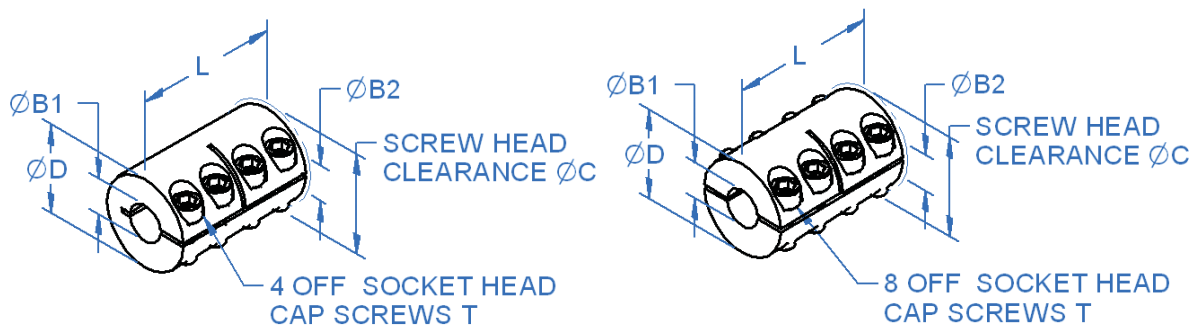

MCLX (1-piece)

MSPX (2-piece)

Associated Products

Shafts
 Bearings
 Leadscrews

Visit our online
 catalogue for
 associated products

Part number selection table

Example Part No:- MCLX-A-3-3			Dimensions (mm)				
Basic Part No.	Material	Size	Standard Bore Sizes ØB1 and ØB2 (bore tolerance +0.05/-0.00)	O/D	Length	Forged Clamp Screw T	
				ØD	L		ØC
MCLX (1-piece)	A (Aluminium)	3	3	15	22	15.0	M2
		4	4	15	22	15.0	M2
		5	5	15	22	15.0	M2
MSPX (2-piece)	SS* (St. Steel)	6	6	18	30	21.5	M3
		8	8	24	35	27.1	M3
		10	10	29	45	33.0	M4

Imperial bores (1/8" to 3/8") available, please enquire.

*Stainless steel is only available on MSPX

Non-standard options, please enquire....

- Non-standard bore sizes, including imperial.
- Set screw clamping.
- Stainless steel screws.

Technical features

- Does not mark the shaft.
- Nypatch® Anti-vibration hardware.
- Precision honed bore.
- MSPX, two-piece style is balanced by opposing hardware and is easily disassembled and maintained.
- Max speed: 3,000 RPM.



Standard Product Sales : ☎ +44 (0)1484 601060 📠 +44 (0)1484 601061
www.rpmechatronics.co.uk sales@rpmechatronics.co.uk

© Reliance Precision Mechatronics LLP

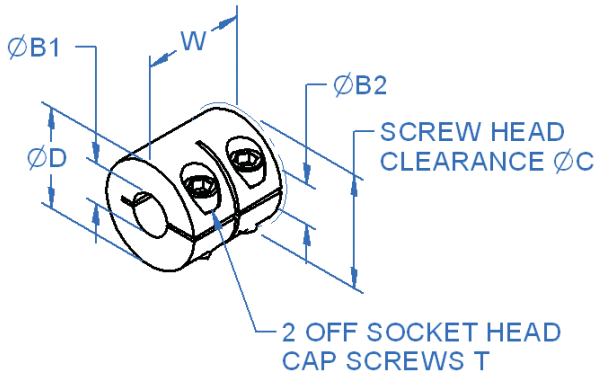

MWCL (1-piece)

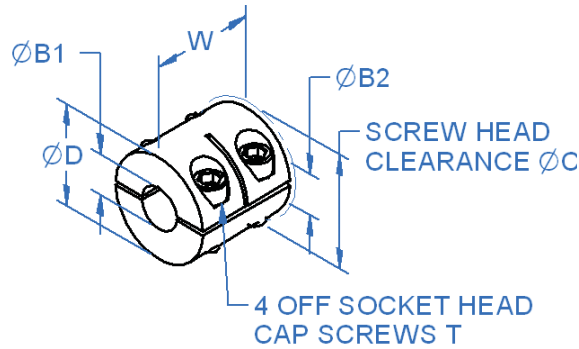

MWSP (2-piece)

General Information

All dimensions in mm
 Manufactured by
 Ruland Corp
 Material:
 Aluminium alloy
 grade 2024.T351
 Stainless steel
 grade 18.8 type 303

Associated Products

Shafts
 Bearings
 Leadscrews

Visit our online catalogue for associated products

Part number selection table

Example Part No:- MWCL-A-6			Dimensions (mm)				
Basic Part No.	Material	Size	Standard Bore Sizes ØB1 and ØB2 (bore tolerance +0.05/-0.00)	O/D	Width	Forged Clamp Screw T	
				ØD	W		ØC
MWCL (1-piece)	A (Aluminium)	6	6	16	20	M3	
MWSP (2-piece)	SS* (St. Steel)	8	8	18	20	M3	
		10	10	24	20	M3	

Imperial bores (1/8" to 1/2") available, please enquire.
 *Stainless steel is only available on MWSP

Non-standard options, please enquire....

- Non-standard bore sizes, including imperial.
- Set screw clamping.
- Stainless steel screws.

Technical features

- Does not mark the shaft.
- Integral location face.
- Excellent for high axial loads.
- MWSP, two-piece style is balanced by opposing hardware and is easily disassembled and maintained.
- Transmits torque in confined spaces.





Clamp Collars

3-10mm Bore

General Information

All dimensions in mm
 Manufactured by
 Ruland Corp
 Material:
 Aluminium alloy
 grade 2024.T351
 Stainless steel
 grade 18.8 type 303

Associated Products

Shafts
 Bearings
 Leadscrews

Visit our online
 catalogue for
 associated products

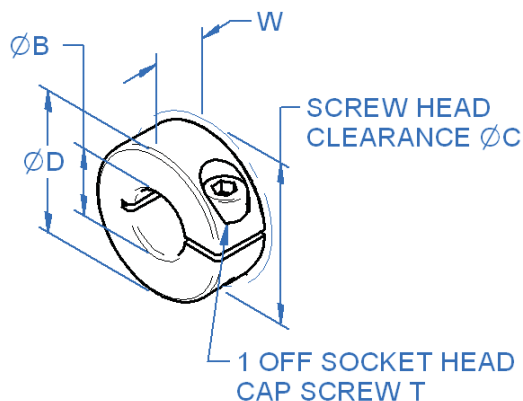

MCL (1-piece)

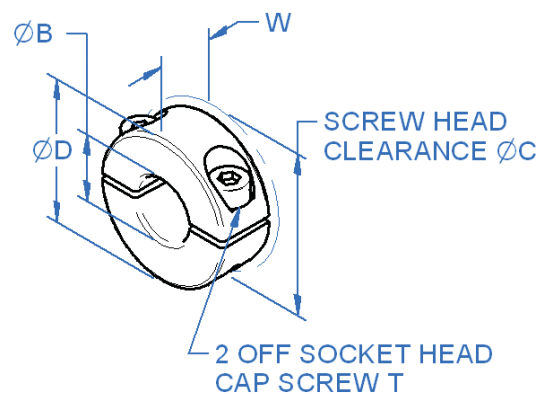

MSP (2-piece)

Part number selection table

Example Part No:- MCL-A-3			Dimensions (mm)				
Basic Part No.	Material	Size	Standard Bore Sizes ØB	O/D	Width	Forged Clamp Screw T	
				ØD	W		ØC
MCL (1-piece)	A (Aluminium)	3	3	16	9	20.8	M3
		4	4	16	9	20.8	M3
		5	5	16	9	20.8	M3
		6	6	16	9	20.8	M3
MSP (2-piece)	SS (St. Steel)	7	7	18	9	22.4	M3
		8	8	18	9	22.4	M3
		9	9	24	9	26.3	M3
		10	10	24	9	26.3	M3

Imperial bores (1/8" to 3/8") available, please enquire.

Non-standard options, please enquire....

- Non-standard bore sizes, including imperial.
- Stainless steel screws.
- Plastic collars available.

Technical features

- Does not mark shaft.
- Integral location face.
- MSP, two-piece style is balanced by opposing hardware and is easily disassembled and maintained.
- Width tolerance: +0.08mm/-0.25mm.
- Pre-drilled face holes.



www.rpmechatronics.co.uk

Standard Product Sales : ☎ +44 (0)1484 601060 📠 +44 (0)1484 601061
www.rpmechatronics.co.uk sales@rpmechatronics.co.uk

© Reliance Precision Mechatronics LLP

One-Piece Threaded Collars

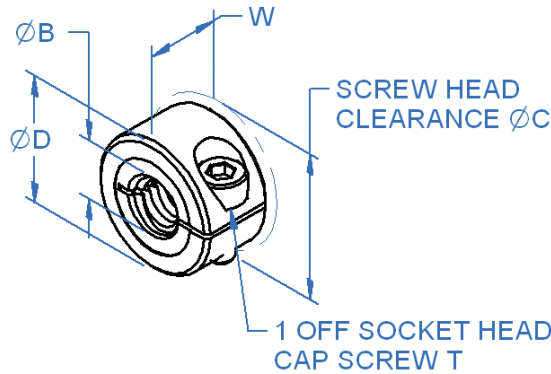

MTCL (threaded)

General Information

All dimensions in mm
 Manufactured by
 Ruland Corp
 Material:
 Stainless steel
 grade 18.8 type 303

Associated Products

Shafts
 Bearings
 Leadscrews

Visit our online catalogue for associated products

Part number selection table

Example Part No:- MTCL-SS-4			Dimensions (mm)				
Basic Part No.	Material	Size	Standard Bore Sizes ØB	O/D	Width	Forged Clamp Screw T	
				ØD	W		ØC
MTCL	SS	4	M4x0.7	16	9	20.8	M3
		5	M5x0.8	16	9	20.8	M3
		6	M6x1	16	9	20.8	M3
		8	M8x1.25	18	9	22.4	M3
		10	M10x1.5	24	9	26.3	M3

Non-standard options, please enquire....

- Non-standard bore sizes, including imperial.
- Stainless steel screws.
- Acme and left-hand threads available.
- Additional sizes available.

Technical features

- Does not mark shaft.
- Integral location face.
- Width tolerance: +0.008mm/-0.25mm.



www.rpmechatronics.co.uk



One-Piece Set Screw Collars

4-10mm Bore

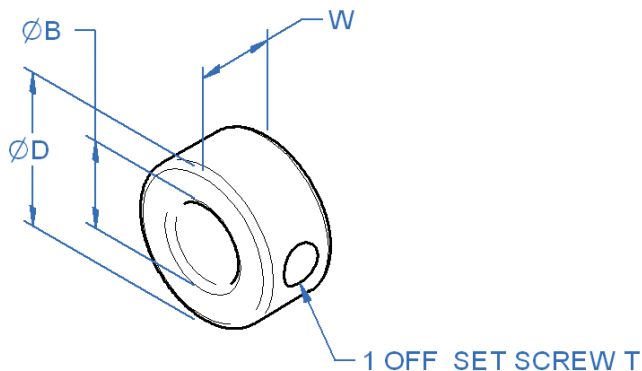

MSC (set screw)

General Information

All dimensions in mm
 Manufactured by
 Ruland Corp
 Material:
 Stainless steel
 grade 18.8 type 303

Associated Products

Shafts
 Bearings
 Leadscrews

Visit our online
 catalogue for
 associated products

Part number selection table

Example Part No:- MSC-SS-4			Dimensions (mm)			
Basic Part No.	Material	Size	Standard Bore Sizes ØB (bore tolerance +0.01/+0.05)	O/D ØD	Width W	Forged Set Screw T
MSC	SS	4	4	8	5	M2.5x3
		5	5	10	6	M3X4
		6	6	12	8	M4X4
		8	8	16	8	M4X4
		10	10	20	10	M5X5

Non-standard options, please enquire....

- Non-standard bore sizes, including imperial.
- Stainless steel screws.
- Plastic collars available.

Technical features

- Forged socket set screw.
- Width tolerances: +0.08mm/-0.25mm.





Picture perfect scanning with Reli-a-Flex® coupling

With the latest advances in digital optical scanning speed, professional flatbed scanner manufacturers are requiring more accuracy from their drive systems. A European company with leading edge technology in drum and flatbed scanners, image setting and integrated media processor products uses Reli-a-Flex® couplings in all their flatbed products. With XY technology, speeds of up to 50 scans per hour and resolutions of up to 5400 dpi, the accuracy and reliability of the Reli-a-Flex® coupling makes it the ideal choice.

Prior to the introduction of the Reli-a-Flex® coupling slight variations in the speed of the CCD element caused errors when trying to capture high resolution images. These errors manifest themselves as a colour registration defect, which resulted in an unacceptable banding effect across the image. Although these errors were small (typically 3.0 microns) they could easily be detected by the naked eye.

The cause of these errors was identified as the flatbed drive system. Introduction of a Reli-a-Flex® coupling manufactured from low inertia Grade 7075-T6 Aluminium was instrumental in bringing these registration defects under control. The unique slit pattern with radial rather than spiral slits gives the Reli-a-Flex® coupling high torsional stiffness and unsurpassed accuracy. However, with Reli-a-Flex® coupling high torsional stiffness does not mean high bearing loads, the Reli-a-Flex® coupling slit pattern has been carefully designed to give low bearing loads in conjunction with its high torsional stiffness.

Also, being tested to 50 million cycles at rated torque, the Reli-a-Flex® coupling is ideal for high duty cycle applications such as busy printing and typesetting applications. All in all the Reli-a-Flex® coupling has proved itself to be ideal for accurate positioning and responsive servo systems.





In the final analysis, Reli-a-Flex® coupling shines through

During development of a new generation of micro plate analysis machines, engineers at a leading European scientific instrument supplier used the Reli-a-Flex® coupling as a critical part of the drive and positioning system.

In line with the industry trend to achieve more accurate, faster machines this particular machine has taken a leap ahead of the competition, being specially developed for life scientists working with very high throughput.

Accuracy and speed of operation of the transport mechanism are critical. Handling plate formats from 96 up to 1536 wells, and the capability to read 1536 wells in less than one minute meant that the correct selection of coupling was essential. Analytical techniques include fluorescence intensity, absorption fluorescence, polarised time delayed fluorescence, and glow luminescence.

The Reli-a-Flex® coupling was chosen as the link between the drive motor and the transport mechanism. High torsional stiffness, low inertia and accurate transmission of motion between the motor and the leadscrew drive were provided by a size 16 Reli-a-Flex® coupling.

The patented slit pattern of the Reli-a-Flex® coupling gives it very high torsional stiffness (comparable to bellows type couplings) whilst still providing very low bearing loads and extremely accurate transmission of motion. In applications requiring more stringent accuracy requirements the Reli-a-Flex® coupling helps the designer by introducing minimal errors of rotation. With a positional error budget of +/- 0.1mm the Reli-a-Flex® coupling was the only choice. Similar one piece spiral slitted couplings can introduce errors of up to +/-0.006mm, however with predicted Reli-a-Flex® coupling errors of only +/-0.001, there was no comparison.

In fact, not only is the Reli-a-Flex® coupling design the stiffest and most accurate one-piece flexible coupling available today, but the patented special slit pattern significantly reduces stress in the flexing elements as the coupling rotates. This ensures that the Reli-a-Flex® coupling is extremely reliable and exceeds the performance of other one-piece slitted couplings. Made from low inertia 7075-T6 Aluminium the Reli-a-Flex® coupling has been fully tested. Life expectancies of greater than 50 million cycles can be readily achieved, making it ideal for today's new generation of accurate, reliable and fast machines.

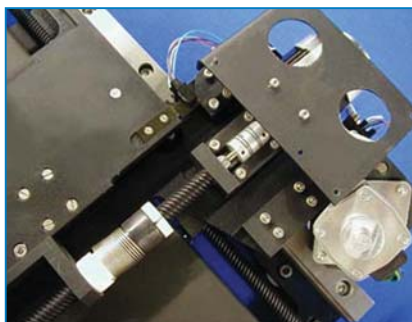



TORSIONAL STIFFNESS

This is the characteristic that describes the angular deflection when a torque is applied. High torsional stiffness contributes to increased accuracy and system response. It is essential for accurate feedback applications. Applications that are subject to shock loads may require a less stiff coupling to reduce the peak torques and avoid premature failure or slipping clamps.

Test samples are standard products with nominal $\varnothing 20.00\text{mm}$

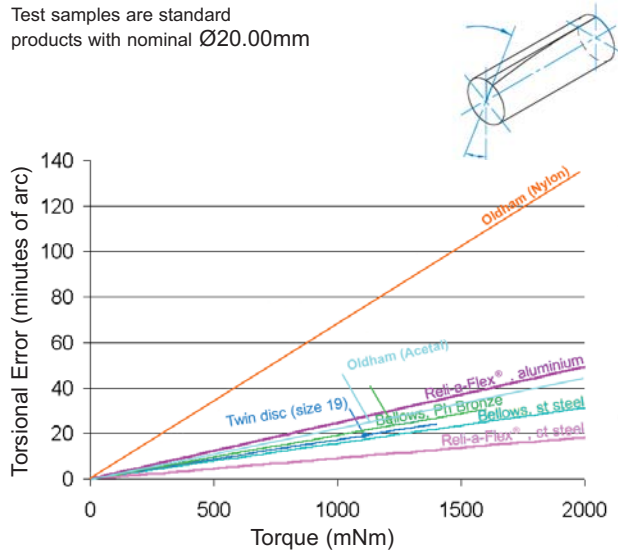

RADIAL COMPLIANCE

This is the characteristic that describes the force the coupling applies on the support bearings when the shafts are misaligned. High radial compliance is essential to provide low bearing loads.

Test samples are standard products with nominal $\varnothing 20.00\text{mm}$

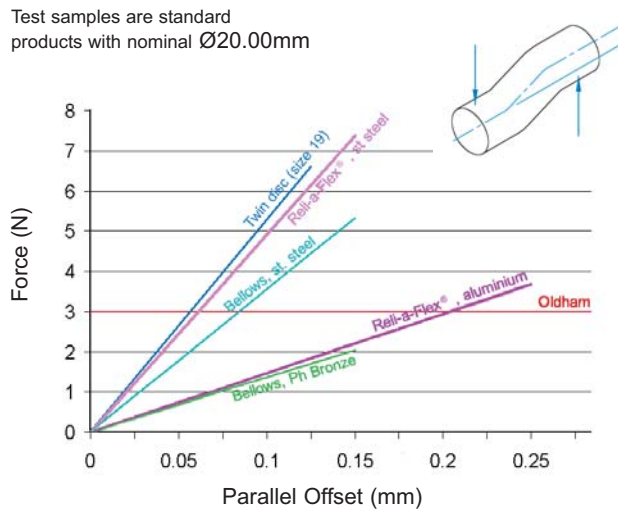

TORQUE CAPACITY

In general, the rated torque figures are based on $>10^6$ torque reversals and the peak torque should not be applied for more than 1% of the duty cycle.

SHAFT MISALIGNMENT

The most common type of misalignment is a combination of angular, parallel and axial misalignment and occurs due to the build-up of tolerances as associated parts are assembled together. As these accumulate randomly, worst-case misalignment should be calculated and used to select the correct coupling to avoid premature failure.

Angular	Parallel	Axial	Combined



TRANSMISSION ERROR

Often referred to as kinematic error, this is the total error in the driven shaft position with respect to the driving shaft position. In a system the following factors must be individually considered to determine their overall effect.

- a. Backlash internal clearance related
- b. Torsional wind up torsional stiffness related
- c. Velocity error coupling design related

a. Backlash

Is the amount of free rotational movement inherent in the coupling under zero or near zero torsional loads. Only the Oldham coupling type in this brochure is susceptible to slight backlash.

b. Torsional wind up

In applications where the resistance is frictional, the driven shaft will experience a position lag, which will double with direction reversal, proportional to the torsional stiffness.

During operating mode, the inertia and the torque will cause a momentary lag but this will not be seen at standstill.

c. Velocity error

In general, couplings with double flexing elements (Reli-a-Flex®, Bellows and Twin disc couplings) will introduce negligible velocity errors.

Velocity errors occur with angular misalignment and are proportional to shaft angle. Only the Oldham coupling type in this brochure is susceptible to this error.

LUBRICATION

This is not required on any of the couplings in this brochure.

FLOATING SHAFTS

We do not recommend the use of couplings in this brochure for floating shafts, where one or both ends of a shaft are supported by a coupling.

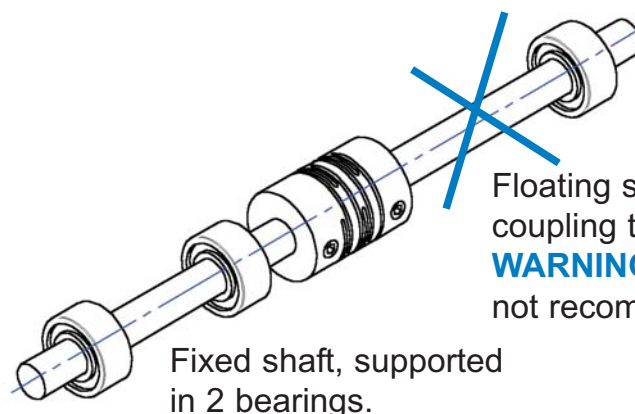

WARNING: This arrangement is not recommended.



TORSIONAL RESONANCE

The torsional natural frequencies of a system are dependent on the mass/elastic characteristics of the various inertias and connecting shafts. Torsional resonance can occur under certain conditions when the natural frequency of the system is close to the excitation frequency of the driving system. It is most likely to occur when the load is predominantly inertial and can occur in closed loop position or velocity control systems, leading to torsional vibrations which in severe circumstances can destroy the coupling.

Choosing a coupling that operates well above or well below the operating frequencies can help to avoid premature failure.

The resonant frequency of a system can be calculated from the following:

$$F_R = 1/2\pi \times \sqrt{(1/J_M + 1/J_L) \times 10.8/\pi \times C_T}$$

- where
- F_R = Resonant frequency (Hz)
 - J_M = Motor inertia (Kgm²)
 - J_L = Load inertia (Kgm²)
 - C_T = Coupling torsional stiffness (mNm/min)

HARDWARE TORQUE TABLE

Clamp Screw	Screw Tightening Torque (Nm)	
	Alloy	Stainless
M1.6	n/a	0.2
M2	0.60	0.4
M2.5	1.21	0.73
M3	2.10	1.10
M4	4.60	2.50

Set Screw	Screw Tightening Torque (Nm)	
	Alloy	Stainless
M2.5	0.57	0.44
M3	0.92	0.73
M4	2.20	1.76
M5	4.00	3.20



RELI-A-FLEX® INSTALLATION

Couplings are available with either clamp or set screw mounting. Clamp fastening, both Reli-a-Grip™ and traditional, allows repeated repositioning of the coupling on the shaft leaving the shaft unmarked. The effectiveness of the clamp is dependent on the diameter being a 'close' fit in the coupling bore. Use of Reliance components will ensure that the clamp works correctly.

Set screws provide an effective but non-adjustable means of connecting couplings and shafts. Ideally the shafts should have a small flat in the area of the screw which allows the set screw to seat below the surface of the shaft.

RULAND COUPLING AND COLLAR INSTALLATION

Oldham Couplings

Assure that the misalignment between shafts is within the coupling's ratings. Slide a hub onto each shaft to be joined with the drive tenons facing each other. Rotate the hubs on the shaft so the drive tenons are located 90° from each other. Place a torque disk so one groove fits over the drive tenons of a hub and center the disk by hand. Insert a shim with the thickness of the coupling's axial motion rating into the groove of the torque disk. Slide the tenons of the second hub into the mating groove in the disk until it touches the shim stock. Fully tighten the screw(s) on each hub to their recommended seating torque. Remove the shim stock to leave a small gap between the top of the drive tenons and the torque disk to allow for axial movement.

Rigid Couplings

Align the coupling on the two shafts to be connected. Tighten the Nypatch® clamp screws in two stages. Starting with the inside screws, tighten to half of the recommended seating torque. Repeat for the outside screws, again tightening to half of the recommended seating torque (on two-piece collars be sure to maintain the gap between the two halves of the coupling during installation). Tighten screws to the full recommended seating torque following the same pattern, beginning with the inside screws.

Shaft Collars

Use collars as they are received.

Wipe the bore clean and apply a thin coat of light oil to the shaft. Place collar in desired location on shaft and tighten the collar until a slight resistance is felt (on two-piece collars be sure to maintain the gap between the two halves of the collar during installation). Bring collar into final position and tighten screws to the full recommended seating torque.

Note - As a result of continuous product development, Reliance reserves the right without prior notice to change dimensions where this does not affect the function of the item. Please visit our website for the latest product news and developments.



International Sales Representatives

**Benelux, Denmark, Austria,
Germany, Switzerland**

Reliance Holland
Klaroenring 217
4876 ZE Etten - Leur
Noord - Brabant
Netherlands
Tel: +31 (0) 76504 0790
Fax: +31 (0) 76504 0791
e-mail: jb@reliance.co.uk

France

Reliance France
33 Rue Racine
11000 Carcassonne
France
Tel: +33 (0)468 470589
Fax: +33 (0)468 471772
e-mail: ph@reliance.co.uk

Australia

Reliance Australia
21 Jubilee Street
Stones Corner
Brisbane 4120
Queensland
Australia
Tel: +61 (0)7 3847 8694
Fax: +61 (0)7 3847 8670
e-mail: grant@relianceprecision.com.au
website: www.relianceprecision.com.au

Hong Kong

Reliance Hong Kong
PO Box 183
Tsuen Wan Post Office-
Hong Kong
Tel: +852 60971149
e-mail: ajw@reliance.co.uk

For our full range of standard and customised components together with a complete overview of Reliance's manufacturing capabilities, visit the Reliance Precision Mechatronics LLP website at:

www.rpmechatronics.co.uk

Standard Product Sales : +44 (0)1484 601060 +44 (0)1484 601061
www.rpmechatronics.co.uk sales@rpmechatronics.co.uk

© Reliance Precision Mechatronics LLP

About Us

Reliance Precision Mechatronics LLP, a sister company to Reliance Precision Limited, was established in 2005 as the distribution arm of the business. In addition to distributing Reliance's existing standard product range, the company aims to design and develop market focused, fully integrated mechatronic assemblies.

Standard Products

For over forty years, Reliance has provided a standard range of precision mechanical components from stock or on short delivery. This service allows design engineers to order in small quantities at stock prices in order to develop prototypes effectively. Dedicated manufacturing facilities enable larger quantities to be supplied for full production requirements.

Reliance Precision Limited (formerly Reliance Gear Company Limited)

Founded in Huddersfield in 1920, Reliance has been under current ownership since 1955. The company specialises in gears, gearboxes, assemblies and associated components used in instrumentation, measurement, diagnostic equipment and light actuation systems. Reliance aims to provide its customers with a single source for the design, production, assembly and testing of high quality mechanical components and electro-mechanical assemblies. Reliance also has over 350 square metres of clean room space for the assembly, wiring and testing of precision gearboxes, optical equipment and scientific instruments to customers' specifications. Particle counts in the clean rooms meet ISO 14644-1 Class ISO 6, but are readily adaptable to more stringent standards if required.

ISO 9001

Reliance Precision Limited and Reliance Precision Mechatronics LLP are both quality assured to BS EN ISO 9001:2000.



Reliance[®]

Precision Mechatronics LLP

Precision Motion Control Components & Mechatronic Assemblies

Rowley Mills, Penistone Road, Lepton
Huddersfield, HD8 0LE, England.

Tel: +44 (0) 1484 601002

Fax: +44 (0) 1484 601061

www.rpmechatronics.co.uk

e-mail: sales@rpmechatronics.co.uk